



» USER'S MANUAL

U.S.A.

**PLEASE READ THIS MANUAL CAREFULLY
CONTAINS IMPORTANT SAFETY INFORMATION**

TILLING MANAGER
437-TM10-D



PREFACE

Thank you for purchasing our KTC-series tilling manager.

The purpose of cultivating the soil is to improve its structure, restore its fertility, improve the surface conditions of the fields and provide a good foundation for the sowing, growth and ripening of the crops during various stages.

Tilling management covers all kinds of operations, from plowing, deep scarification, soil crushing, ditch digging, bedding, film laying, weeding, hilling up, pesticide spreading, harvesting, etc. KTC series tilling manager is a new type of tilling machine that can do all the above tilling operations. The designers have taken full consideration of the different requirements of different crops for tilling tools, so that the machine can meet different conditions and perform wonderfully in dry fields, paddy fields, hilly regions, flat areas and big sheds. It can work with high efficiency and perfect results in fields or gardens for vegetables, fruits, flowerbeds, seedlings, tobacco, tea and herb. It is equally good for common crops and cash crops. It can effectively reduce labor intensity, improve working efficiency and bring in more income.

In order to better use the machine and understand all the safety precautions, it is advisable to read this instructions manual carefully. You will be able to use the machine to the best effect if you are familiar with the instructions in this manual and operate the machine correctly.

Please keep this manual in a safe place after reading it carefully. If this manual is lost or damaged, you may contact our company or our agent or appointed sales representative for purchasing a new one. If you have any problems or are not clear about anything, please consult our agent or sales representative. If you need help when you meet with any problems you cannot solve by yourself in using the machine or want to have your machine serviced or repaired, please contact our local sales representative or appointed service center.

INDEX



	Page
Preface	
Safety Precautions	
● Chapter 1 Description of the Parts and Major Specifications.....	15
1.1 Description of the Parts	
1.2 Major Specifications	
1.3 Positions of Safety Reminders	
● Chapter 2 Functions of Different Units	20
2.1 Function of the Starting Unit	
2.2 Function of the Driving Unit	
2.3 Function of the Operating Unit	
2.4 Function of Other Units	
● Chapter 3 Correct Operation and Use.....	25
3.1 Correct Starting Method	
3.2 Correct Operation	
3.3 Correct Assembly and Use	
3.4 Safety Precautions in Use	
● Chapter 4 Maintenance.....	39
4.1 Daily Maintenance	
4.2 Periodic Maintenance	
4.3 Adjustment and Maintenance of Different Units	
4.4 Storage	
● Chapter 5 Fault Finding.....	50

Safety Precautions

To make sure that you use the machine correctly and safely, we put a special chapter here named SAFETY PRECAUTIONS. Please read this section carefully before using the machine. Should you break these safety precautions, it might lead to serious damage or even accidents, including personal injury or casualty.

1. Safety Precautions in Operation

Operators in any of the following cases must be prohibited from operating the machine.

- * He or she is tired or sick and unfit for operating the machine.
- * He or she is drunk.
- * She is pregnant.
- He or she is not grown up.



Operators must be well protected before operating the machine.

- * They must wear safety shoes.
 - * They must wear safety caps.
 - * Anything tied around their bodies must be kept tight without leaving any part hanging out.
- They must not wear scarves, kerchiefs, or aprons that might have the danger of getting caught in the machine.



Anybody borrowing the machine must be instructed to read this manual carefully.

- * If the machine is lent to somebody, he must be instructed to read this manual carefully.
- Otherwise, it might lead to serious damage, accidents, injury or casualties.



Ploughshares that do not match must not be assembled on this machine.

- Any ploughshares that do not match this machine must not be used, even after modification. Otherwise it might lead to faults, accidents or even casualties and injuries.



2. Cautions that must be taken care of before operating this machine.

Refilling can be done only after the engine has cooled down. Smoking must be prohibited and flame must not be brought near in the process of refilling. Violation of this rule might lead to a serious fire.



In wintertime, when the machine is to be started indoors, good ventilation must be kept, in case contaminated air affects the health or leads to poisoning.

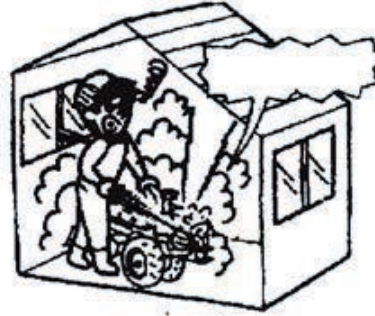

Everyday, before starting the machine, care must be taken to remove the weeds or rubbish that get caught around the muffler or engine, because they might lead to overheat and damage the machine. At the same time, all covers or caps must be checked carefully to make sure that they are kept tight and free from rubbish.



Everyday, before operation, the machine must be checked carefully to see if the clutch control levers and other controls can move freely. Adjustment must be made if they cannot do so, so that they can be operated safely and reliably. Otherwise, mechanical faults or accidents might occur.



3. Cautions in the Process of Loading and Unloading

The steering handles or the main clutch control lever must never be operated when the machine is running on a stepping board.

At the time of using the machine to load and unload with the help of a stepping board, it must be operated at the slowest speed. The operator must not take a turning, or change the route or stop on the board. Operation of the steering handles and main clutch control lever must be strictly prohibited. The main speed change lever must not be put in the "neutral" (idle) position. Stop the machine immediately should any emergency occur. Otherwise accidents such as falling down might happen.

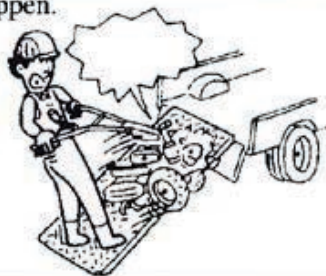

The stepping board must have sufficient strength, proper length or width.

When the machine is used to load and unload, the operation must be done at flat and safe places. The engine must be stopped and the body of the truck must be fixed tight. The stepping board used must have sufficient length, width and strength. Slippery boards must not be used to prevent accidents

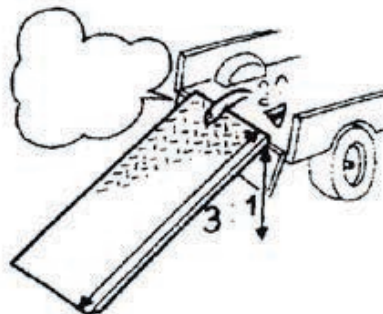

At the time of doing loading and unloading, nobody must be allowed to stand in front of the machine.

At the time of doing loading and unloading, nobody must be allowed to stand in front of the machine. Otherwise injury or casualty might occur.

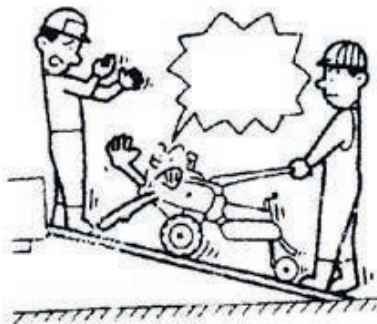

Heading forward at the time of going up and backward at the time of coming down. At the same time, the machine must be tied to the truck with a rope.

At the time of loading, the machine must be operated in the forward direction and at the time of unloading, it must be operated in the reverse direction. In the process of transportation when the machine is put on a truck, it must be fixed tightly with a rope to prevent falling down.

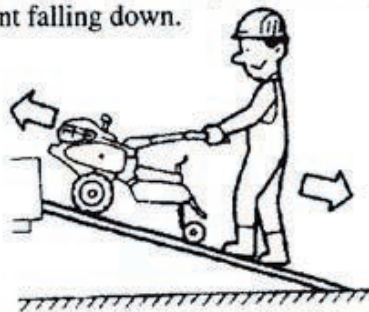

4. Precautions in the Process of Operation

A stepping board must be used when the machine is crossing a water ditch or a ridge in the fields.

When the machine enters a paddy field, crosses a water ditch or a place where the soil is too soft, a stepping board must be used. The machine must run at the lowest speed, and the stepping board must have proper length, width and strength that can meet the operation of this machine. The steering handles, the main clutch control lever or the main speed change lever must not be operated. Otherwise there might be a slip or tilt-over of the machine, which might lead to serious damage or accidents.



The machine must not be moved forward abruptly at high speed, abruptly stopped, or abruptly turned. It must not be operated at over high speed.

The machine must be started and stopped slowly, and must be slowed down when it goes around a turning. On downward slopes or rugged roads, it must be slowed down too. Otherwise, damage or accidents might occur.



Mind steps on the road while running the machine

In the countryside, on roads where there are water ditches or their sides present a slope shape, good care must be taken of the steps on the roads. Otherwise the machine might fall down.



Never operate the rotary tiller or any other operating machines when the machine is running.

In operations using the rotary tiller, never operate it when the main machine is operating. Otherwise the operator might be caught by the rotary tiller blades, which might lead to injury or casualties.



On rugged or soft roads or roads with crosswise water ditches, the machine must be operated at very low speed.

When the machine is going on a downward slope or on rugged roads or on roads with many crosswise water ditches, it must be operated slowly. Otherwise, it might have the risk of falling over, falling down or having other accidents.



While operating the machine, the operator must not turn his eyes to other things or let go his hands.

While operating the machine, the operator must concentrate his attention on the operation. He must not turn his eyes to other things or let go his hands. Otherwise, accidents might occur.



The operator must not put his hands or feet under the rotary tiller or any other operating machine while the engine is running.

The operator must never put his hands or feet under the rotary tiller or any other operating machine. Otherwise injury or death might occur.

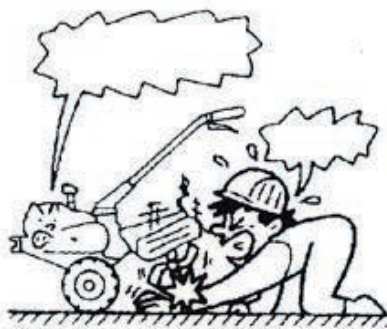

The working place must be well ventilated when the machine is working indoors.

When the machine is working inside a big shed or indoors, particular attention must be paid to good ventilation, especially in wintertime. Otherwise the air emission might be harmful to the health or even cause injury.



The operator must not stand and operate behind the rotary tiller when it is backing.

As shown in the picture, the claws of the rotary tiller are rotating in front of the operator while he is operating the machine in the backward direction. This is strictly prohibited. He must turn the handle around at 180 degrees and move forward. Otherwise, he may have the danger of being caught between the machine and an obstacle, and should there be a tilting, he might be caught into the rotary tiller. In both cases, serious injury might occur.



Other people or animals must not get near the machine.

While the machine is in operation, other people, children in particular, or animals must be kept at a distance. Otherwise unexpected accidents or injury might occur.



Particular attention must be paid to unexpected accidents when the machine is moving at high speed or abruptly.

While operating the rotary tiller or performing any half-axis operations, take particular care because the rotary tiller might jump up unexpectedly when it suddenly strikes against a hard ground or a stone while moving fast or abruptly. Particularly, when the machine is working by a river, a ditch or a cliff or some people are nearby, serious injury or dropdown might occur.

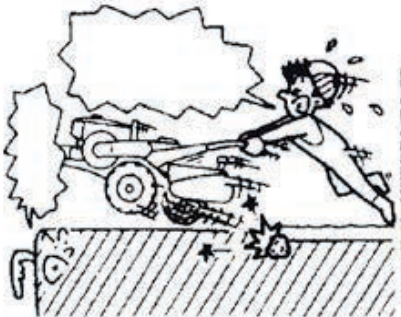

Rotation of the rotary tiller must be stopped when it is moving backward.

While operating the rotary tiller, its rotation must be stopped when it is moving backward. Otherwise the operator might be caught by the rotating claws, which will lead to serious injury or casualty.



Before starting the machine, the operator must be sure that there is no potential danger in the surroundings.

Before starting the machine, the operator must make sure that all the control levers are set at correct positions and the surrounding is perfectly safe.

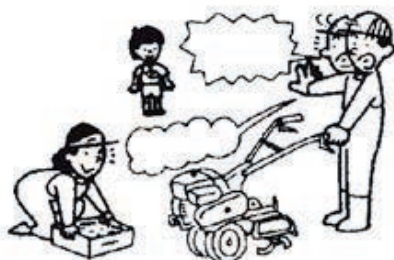

The operator must stop the machine before he tries to clear the claws of mud and weeds.

If it is necessary to remove mud or weeds from the machine during the operations, he must stop the engine first. Otherwise serious injury or accidents might occur.



The steering handles must not be used when the machine is operating on a slope.

While operating on a slope, the operator must extend the wheelbase to prevent the machine from turning over. If he wants to take a turning, he must use the manual handle instead of the steering handles. Otherwise the machine might have the danger of turning over and causing accidents or injury.

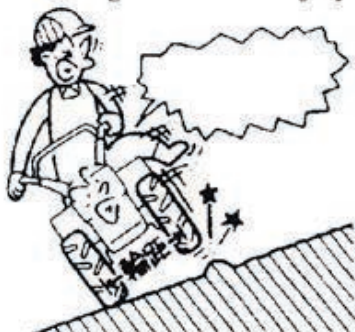

Before turning the manual handle to the opposite direction, the left or right turning handle must be switched over.

This machine is equipped with a turning switchover device. When the operator wants to turn the manual handle to the reverse direction, he must use the turning switchover device to make a switchover between the handles, so that he can take turnings in the same way as his usual habit.



5. Precautions while the machine is running

Trailers bigger than the specified dimensions or without a brake must never be used. If necessary, a rear reflector, a backing mirror or a trumpet might be installed.

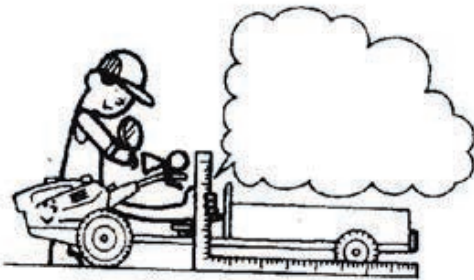

The running speed of the machine must be limited under 15 kilometers per hour. This limit must never be broken after the belt pulley of the engine or the wheels (including paddy field wheels) are changed.

The load in the trailer is limited to 500 kilograms. This limit must not be broken either.

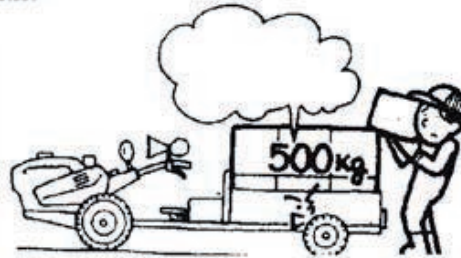

Before starting transportation, all the screws and nuts must be tightened. Check the pressure of the tire carefully and make sure that it is around 1.2 kg/cm². Adjust the brake of the trailer and make sure that it works effectively in both directions (right and left).

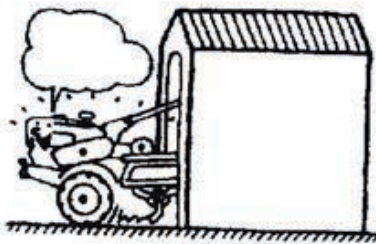

While the machine is running at high speed, to bring it to a stop, the brake of the trailer must be applied slowly after the throttle is closed down.

When the machine is hooked with a trailer and running down a slope, if the brake of the trailer is applied, the weight in the trailer might move toward the operator, which is very dangerous. At a turning, the machine must be slowed down and the manual handle must be used. At this time, use of the steering handles is strictly forbidden.



Chapter 1 Description of the Parts and Major Specifications

1.1 Description of the Parts

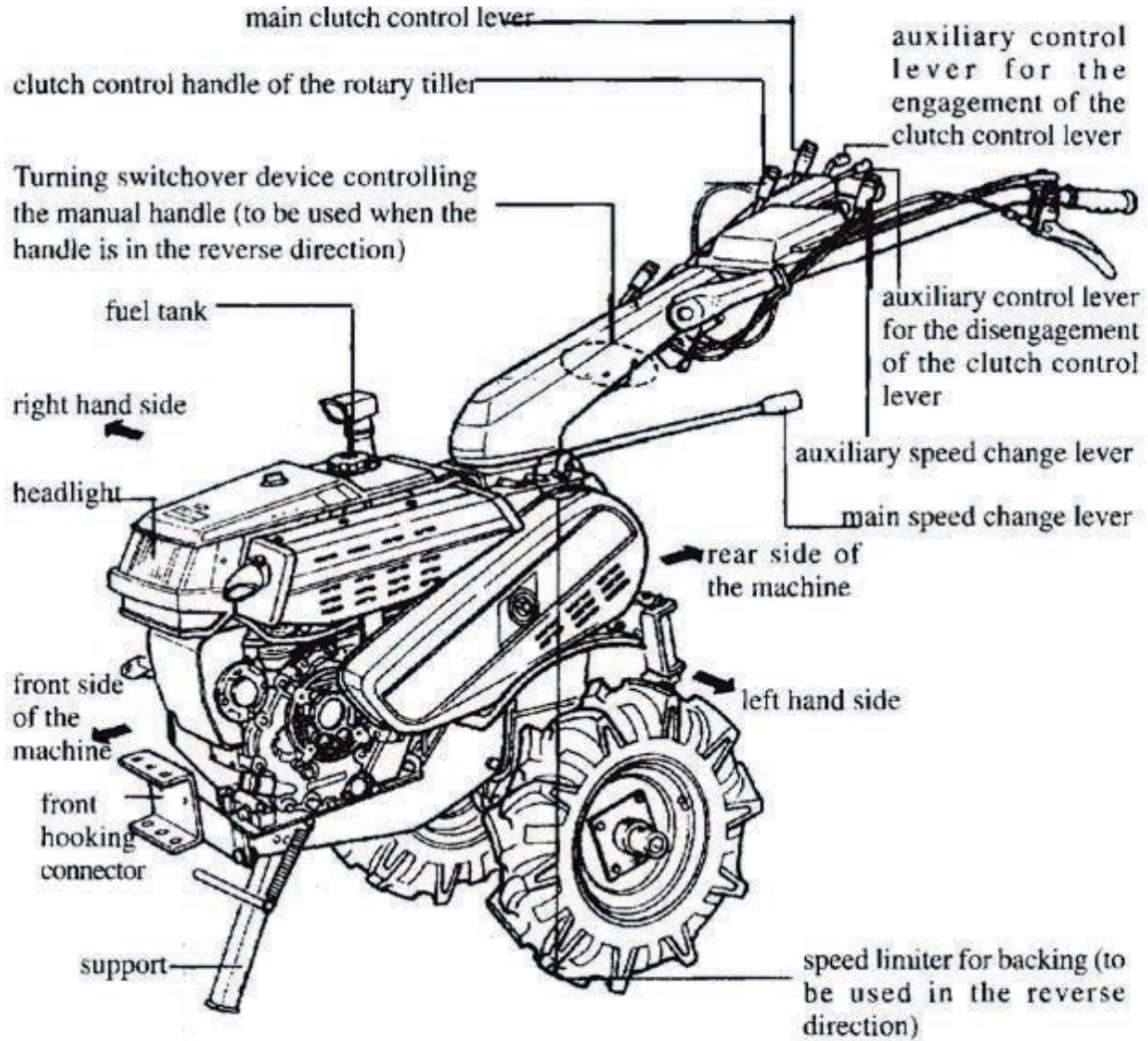

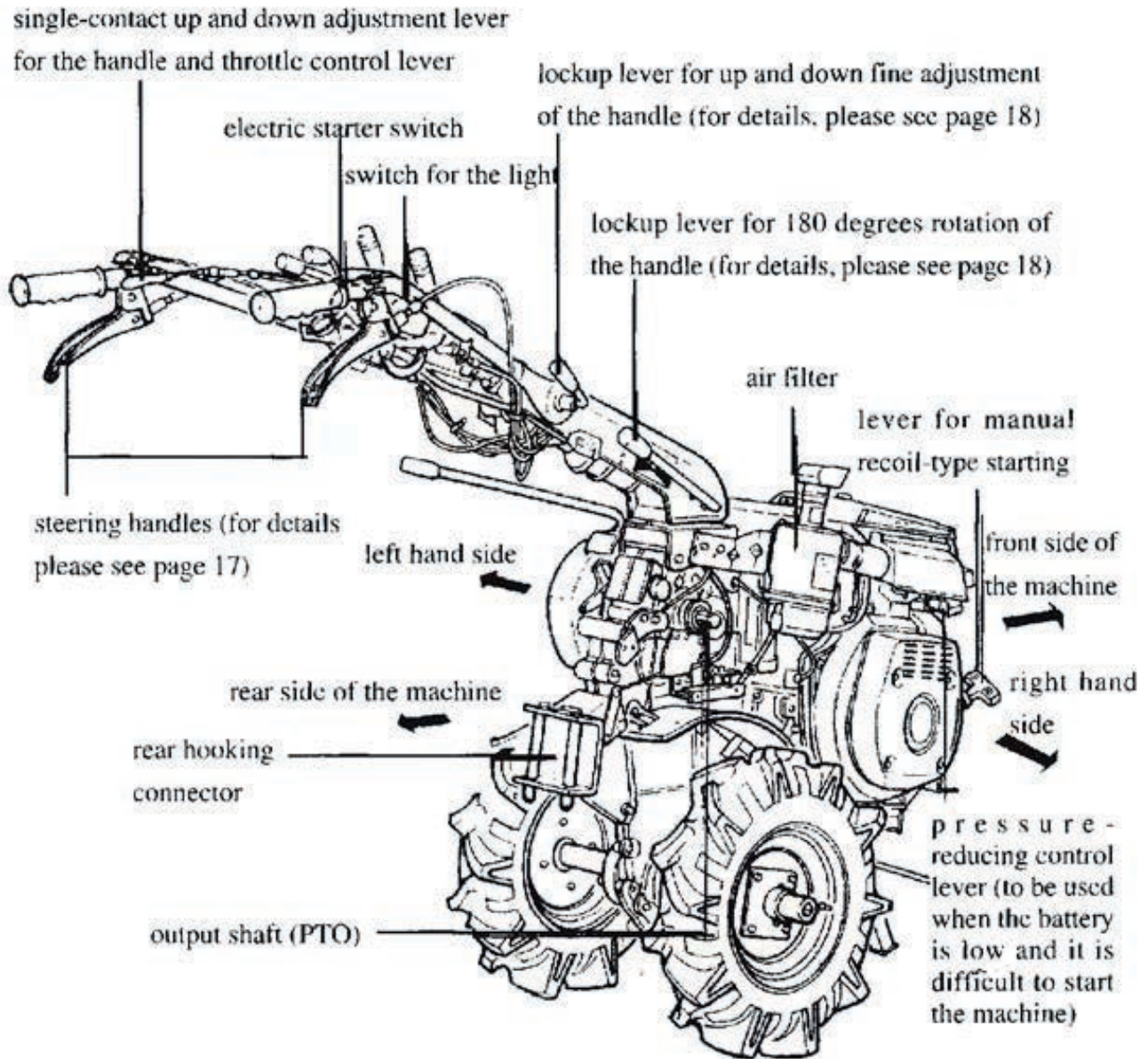

1.2 Major Specifications Description major Specifications of KTC-Series Tilling Manager

MODELO	437-TM10-D
	CHARACTERISTICS // CARACTERÍSTICAS
	Hexagonal Cylindrical Hoe // Azada Cilíndrica Hexagonal
Accessories // Accesorios	Different Accessories Adapter // Adaptador Diferentes Accesorios
	Reverse Speed Limiter // Limitador Velocidad en Reversa
	Distance Between Wheels Adjustable // Distancia entre Ruedas Ajustables
Plowtail Rotation // Giro Manceras	180°
Output shaft rotation speed (rpm) // Velocidad Rotación eje Salida (rpm)	700
Gear Box // Velocidades	3 Forward - 1 Reverse // 3 Adelante - 1 Atrás
Distance Between Wheels (mm) // Distancia Entre Ruedas (mm)	206 - 640
Clutch Type // Tipo de Embrague	Manual Control – Main Clutch // Control Manual Clutch Principal.
	TECHNICAL SPECIFICATIONS (MOTOR) // ESPECIFICACIONES TECNICAS (MOTOR)
Motor Model // Modelo Motor	437-186FS
Motor Type // Tipo de motor	4 Stroke // 4 Tiempos
Power (hp) // Potencia (hp)	9.0
Power (Kw) // Potencia [Kw.]	6.6
Rotational Speed (rpm) // Velocidad (rpm)	1800
Lubricating System // Sistema de Lubricación	Pressure splashed // Presión, Salpicado.
Starting System // Sistema de Arranque	Manual // Manual
Cooling System // Refrigeración	Cooled Air // Refrigerado por Aire
	CAPACITY AND CONSUMPTION // CAPACIDADES Y CONSUMOS
Oil Tank Capacity (L) // Cap. Tanque Aceite (L)	1.65
Oil Tank Capacity (gal) // Cap. Tanque Aceite (gal)	0.44
Fuel Tank Capacity (L) // Cap. Tanque Combustible (L)	5.5
Fuel Tank Capacity (gal) // Cap. Tanque Combustible (gal)	1.45
Autonomy (h) // Autonomía (h)	2.0
Lube Oil Type // Tipo de Aceite de Lubricación	SAE10W30
	DIMENSIONS AND WEIGHT // DIMENSIONES Y PESOS
Length x Width x Height (mm) // Largo x Ancho x Alto (mm)	1770 x 645 x 1040
Net Weight (Kg) // Peso Neto (Kg)	160
	ACCESSORIES SOLD SEPARATELY // LOS ACCESORIOS SE ADQUIEREN POR SEPARADO

* Our factory reserves the right to change the design and sizes without previous notice, in order to improve the performance of our products.

* E - equipped with battery starter device.

1.3 Positions of Safety Reminders

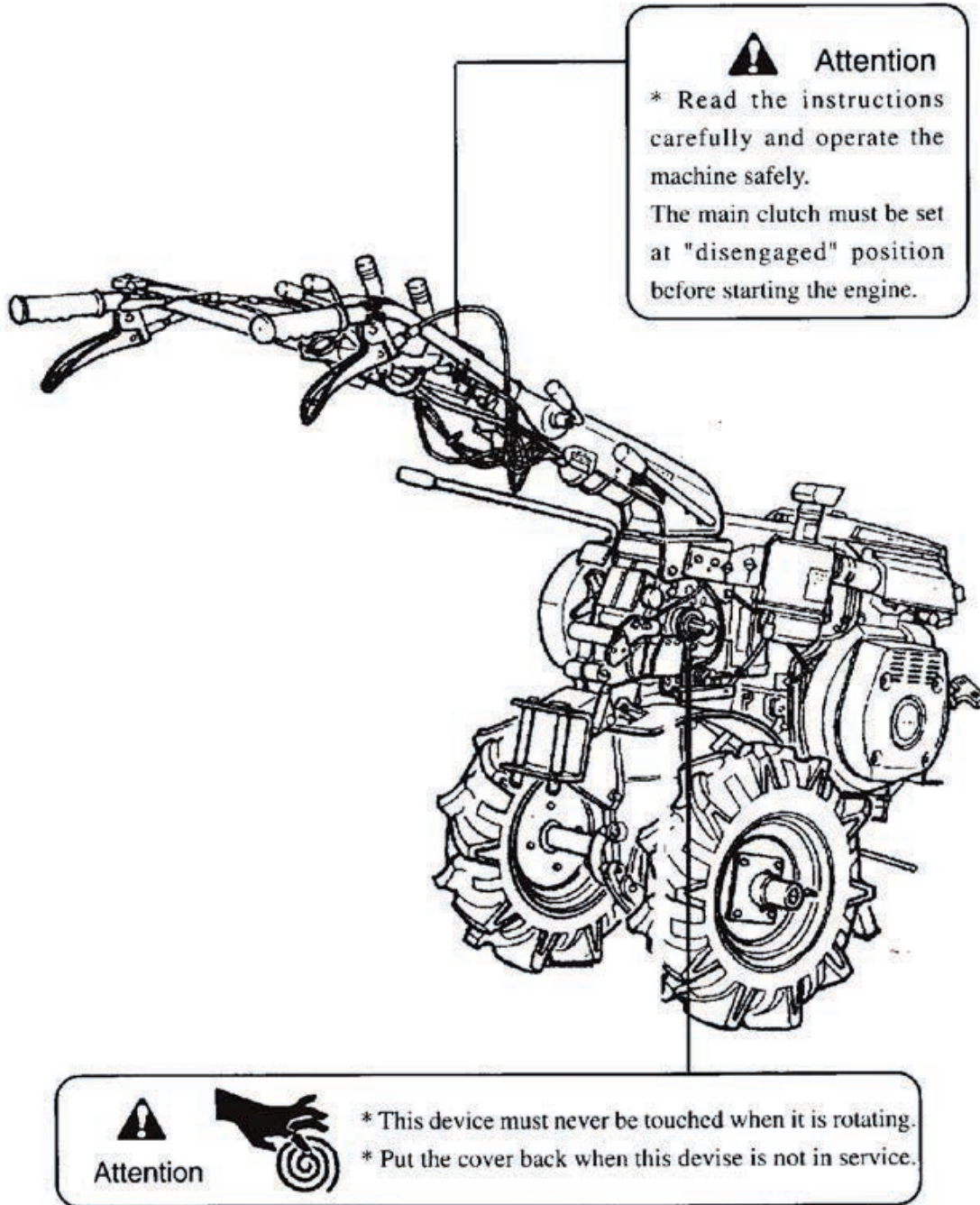

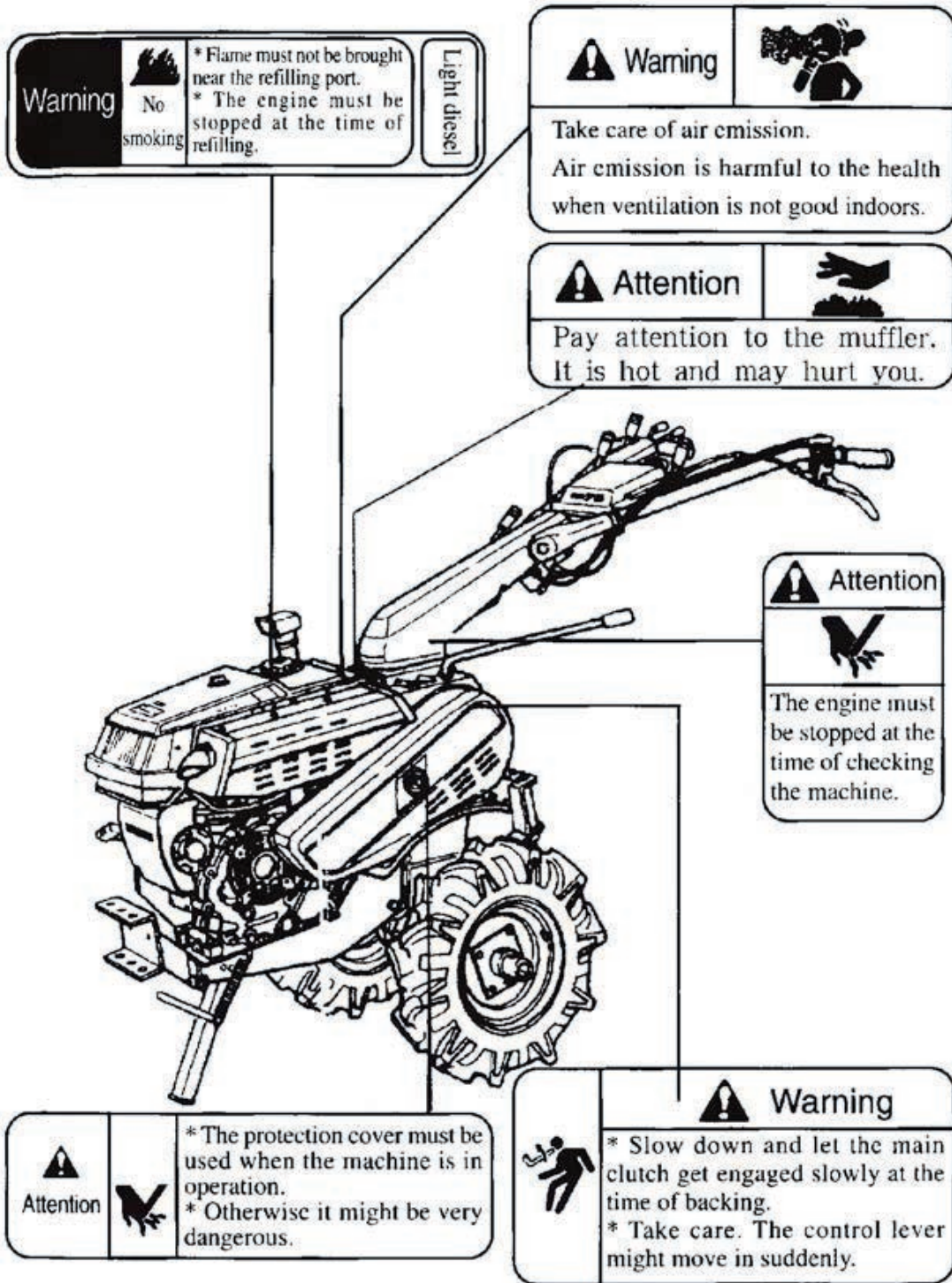

The safety reminders must be put right or replaced if they are damaged or drop down, or if their colors are faded.

Chapter 2 Functions of Different Units

2.1 Function of the Starting Unit

Please get familiar with the names and functions of all the units and learn them by heart.

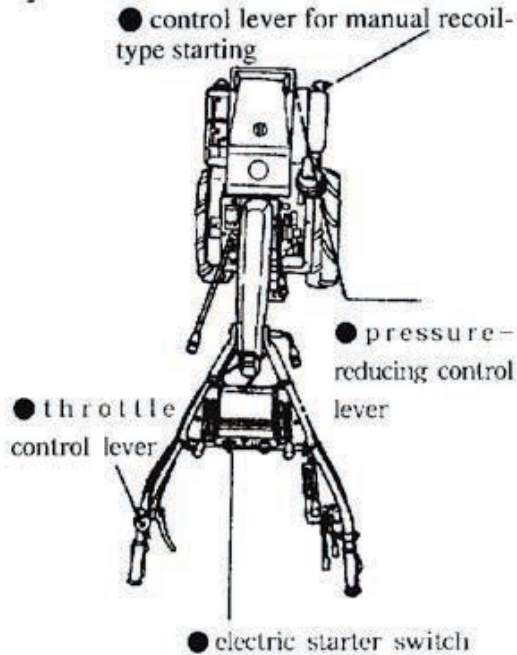

1. Electric Starter Switch

This switch is used at the time of starting or stopping the engine.

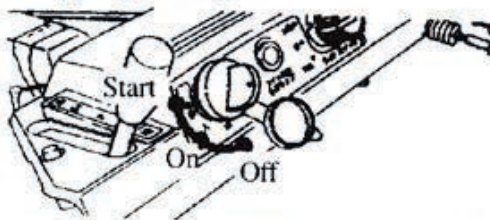

When it is put to "Off", the engine will be stopped and when it is put to "On", the engine will be running.

When it is put to "Start", the battery will start the motor so that the engine starts running.

2. Throttle control lever

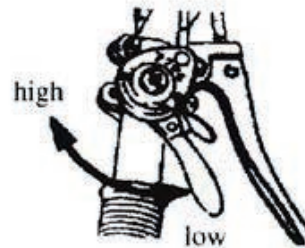

This lever is used when it is necessary to adjust the speed of the engine. The throttle must be put in the "High" position at the time of starting the engine and back to the "Low" position before shutting down the engine. It might be set at any position as required when the machine in operation.

3. Control lever for manual recoil-type starting

When the engine is to be started, pull up this manual lever, in a way as detailedly described in the instructions manual of the diesel engine.

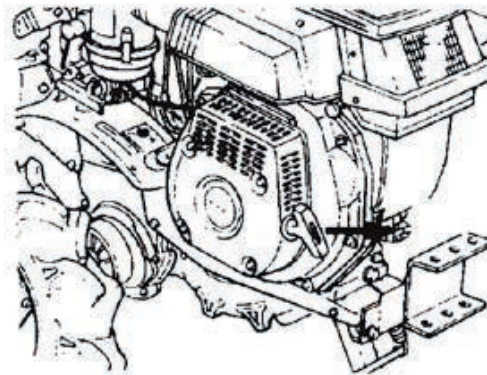

4. Pressure-reducing control lever

This lever can be used at the time of starting when the battery is low and it is difficult to start the engine.

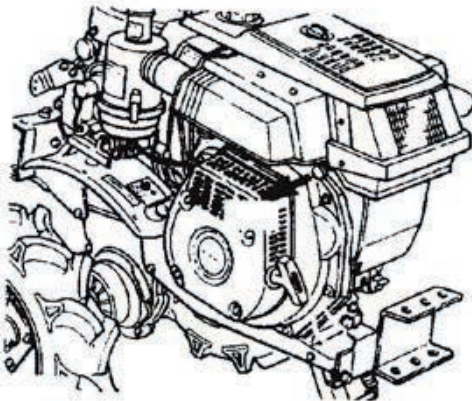

2.2 Function of the Driving Unit

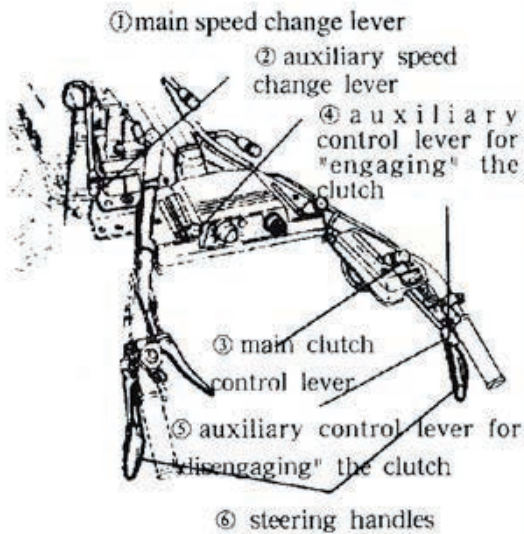

1. Main speed change control lever

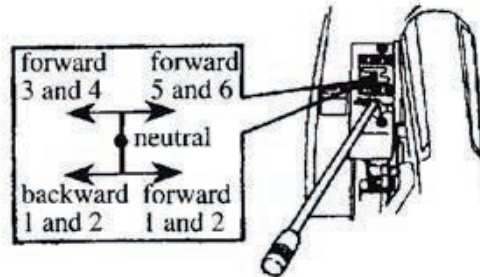

This lever is used when it is necessary to change the running speed of the machine. There are six forward steps, two backward steps, two forward steps for auxiliary speed change and two backward steps for auxiliary speed change.

2. Auxiliary speed change lever

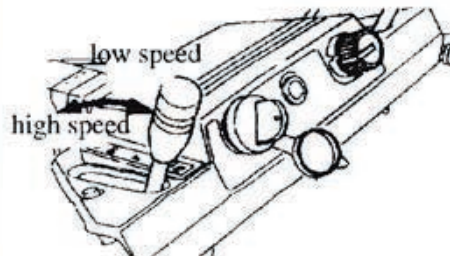

This lever is used for changing the running speed from high to low or vice versa.

* When it is intended to change from low speed to high speed, it is necessary to slow down the engine with the throttle control lever first.

3. Main clutch control lever

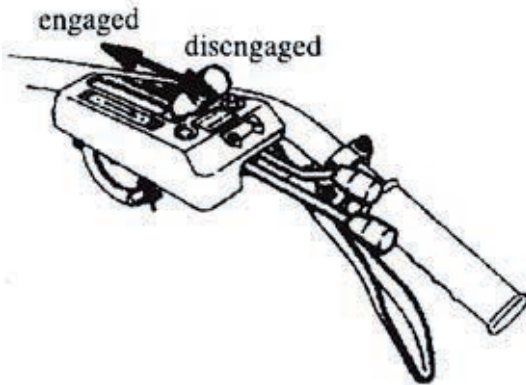

This control lever serves to start or stop the power transmission from the engine to the gearbox.

4. Auxiliary control lever for "engaging" the clutch

5. Auxiliary control lever for "disengaging" the clutch

These two levers can be operated with the right thumb to help the operation of the main clutch when the hands are holding the handle.

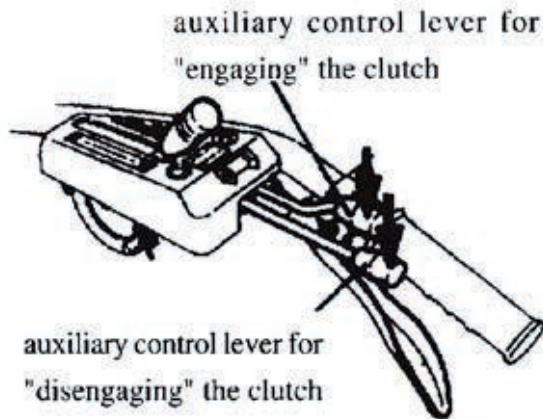

6. Steering handles

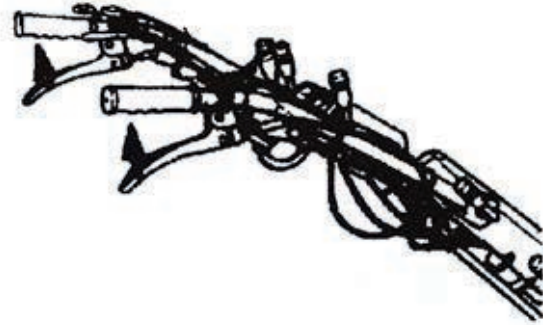

The right and left steering handles are independent from each other. When the hand presses the handle (as shown by the arrow in the picture), the wheel on the corresponding side stops rotating, so that the machine turns to the side on which the handle is pressed.

2.3 Function of the Operating Unit

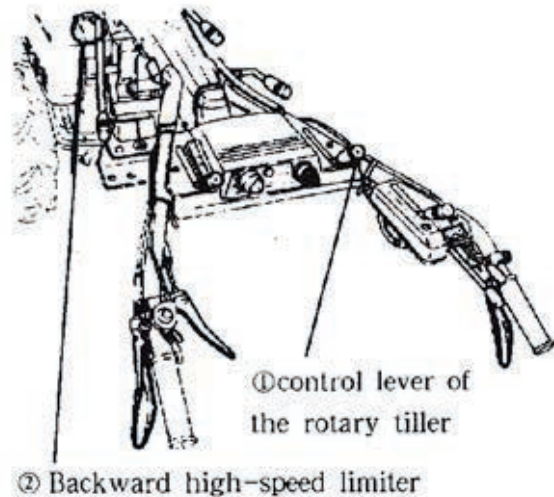

1. Control lever of the rotary tiller

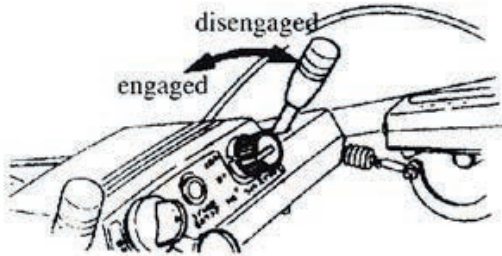

This lever serves to start or stop the power transmission from engine to the rotary tiller.

2. Backward high-speed limiter

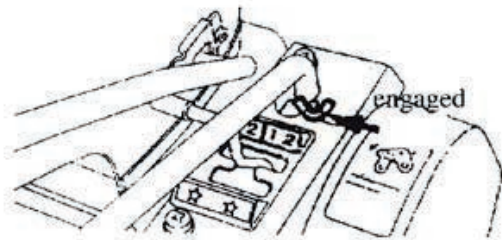

This limiter should be put to the "On" position to control the backing speed when the handle is pushed to the "reverse" direction.

2.4 Function of Other Units

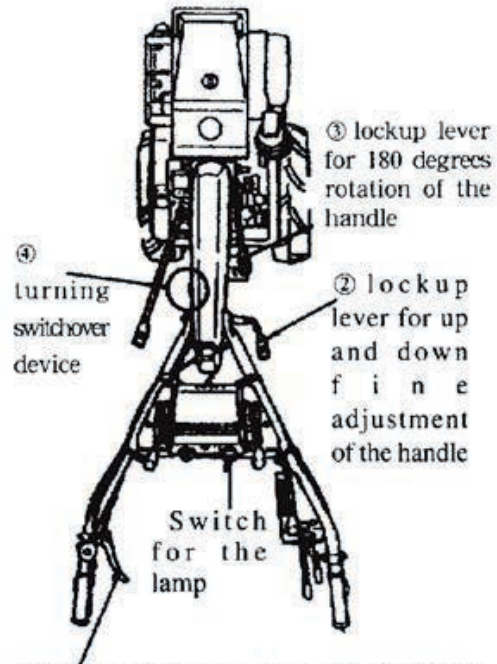

① Single-contact up and down adjustment lever for the handle

1. Single-contact up and down adjustment lever for the handle



This lever serves to make big up and down adjustment of the handle. The adjustment can be made in three steps.

2. Lockup lever for up and down fine adjustment of the handle

It serves to adjust the height of the handle when the handle is fixed.

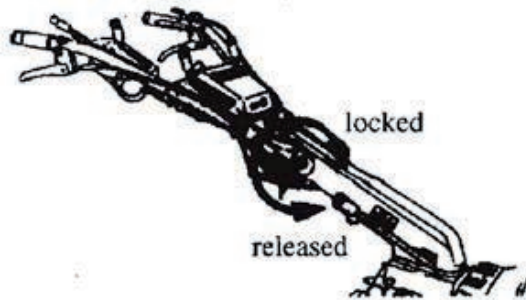

3. Lockup lever for 180 degrees rotation of the handle

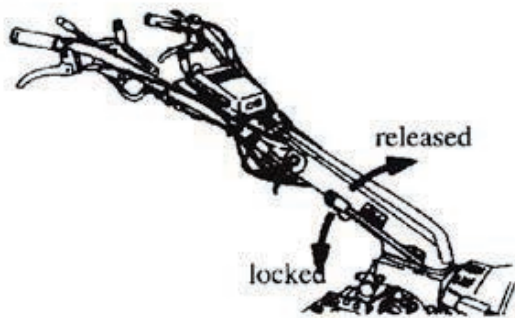

When the handle is released, it can be adjusted freely within the range of 180 degrees to the left and 30 degrees to the right.

4. Turning switchover device for switchover between the left and right turning handles

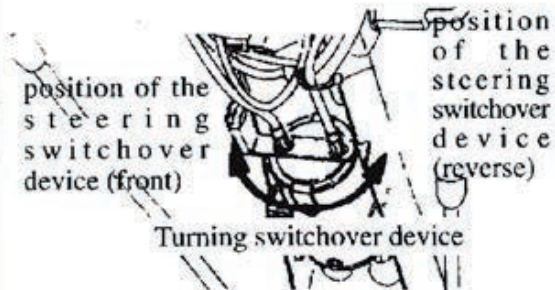

When the turning switchover device is turned to the front or reverse position, it can switch the steering handles between right and left.

5. Switch for the lamp

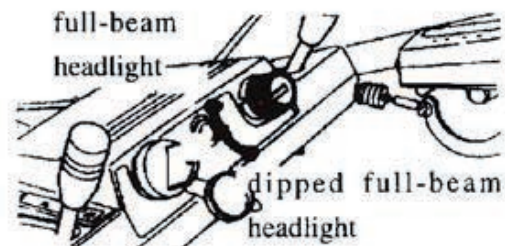

This switch serves to turn on the headlights and the light for the control panel for illumination. The headlights include full beam and dipped.

Chapter 3 Correct Operation and Use

3.1 Correct Starting Method

1. Normal check before operation

① Positions where abnormal conditions occurred the previous day.

② Rotate and shake the tilling manager a little.

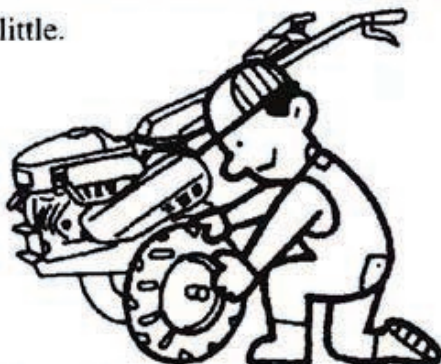

To check if there is any deformation, damage or contamination in all the units. Check the tires for the pressure and any possible damage, as shown in Page 42. Check the muffler and other overheated units to see if there is any dirt or dust. Check the wires or cables for any damaged insulation or loose connection.

Check all the units for any possible damage. Check the screws and nuts for any loosening. Check the fuel tank and the lubrication tank for the liquid levels as shown on Page 37.

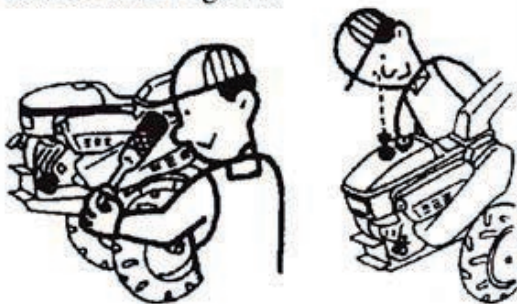

Check the air filters to see if there is any contamination as shown on Page 38.



③ Check the handles or levers to see if they can move freely, as shown on Page 17.

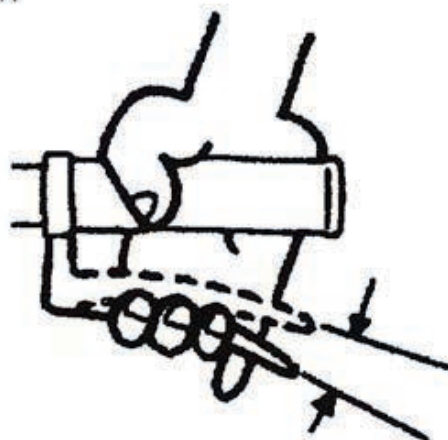

④ Try starting the engine to see if there is any abnormal noise or abnormal color in air emission.



Check all the handles and levers to see if they can move reliably.



2. Fuel check and refilling method

Check: Check the liquid level with the dipstick in the fuel tank. If the fuel level is found to be too low, fill the tank through the refilling port on top.

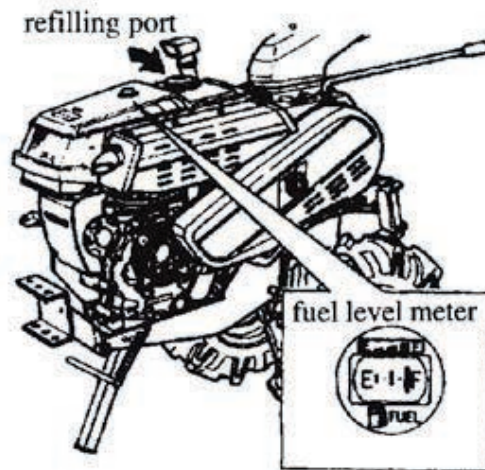

For detailed description about the fuel refilling, please refer to the Pages 1 and 14 in the instructions manual for the F series diesel engine.

3. Check and replacement of lubricating oil in all units

The mobile oil in the engine and the gear oil in the gearbox cannot be used permanently. Otherwise it might deteriorate the mechanical performance and cause malfunction. It is necessary to discharge the waste oil periodically and refill with new oil.

① Replacement of engine mobile

For details, please refer to Pages 14, 15 and 23 in the instructions manual for the F series diesel engine.

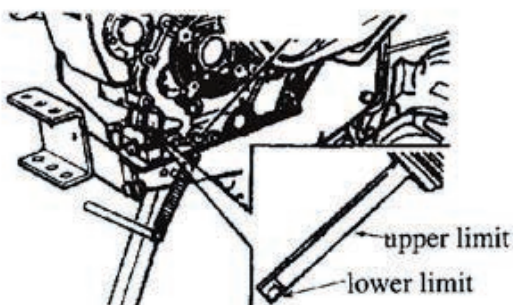

Attention

* The oil level can be checked only after the engine has been shut down.

* The front support under the frame must be let down at the time of refilling, so that the engine is put at a horizontal position.

② Gear oil in the gearbox

Check: Check if there is any leakage.

Replacement: remove the oil discharge plug at the bottom of the gearbox so that all the waste oil flows out. Then refill until the oil overflows from the oil check screw.

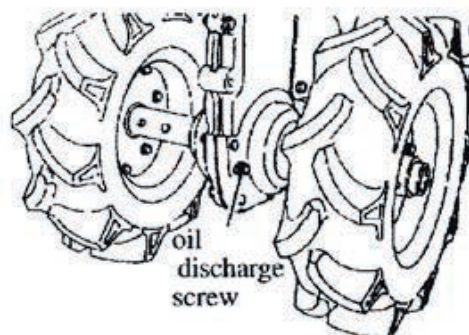
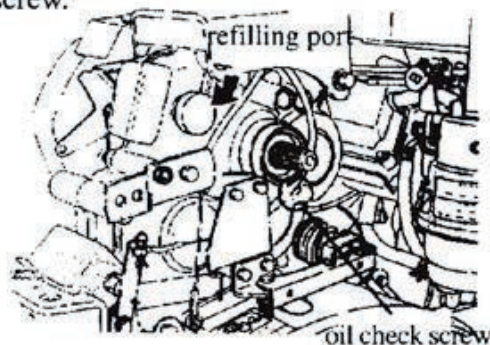

4. Method of starting and shutting down the engine

① normal starting

* Put the main clutch control lever to the "disengaged" position.

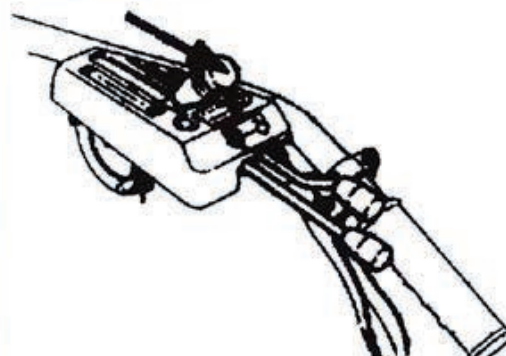

* Put the main speed change lever to the neutral position.

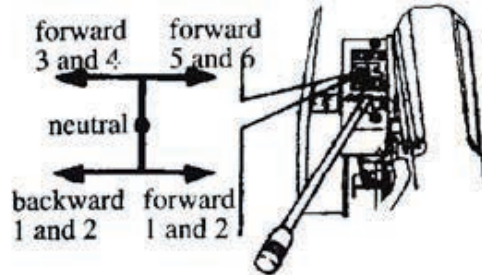

* Put the lever of the fuel on/off switch to the "on" position.

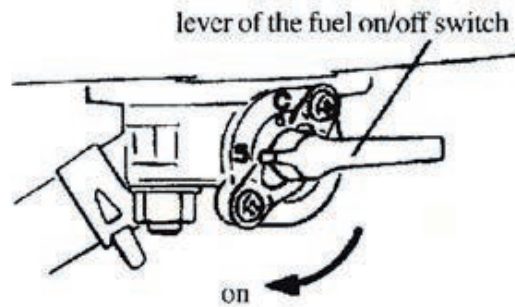

* Set the throttle control lever to the "high" position.

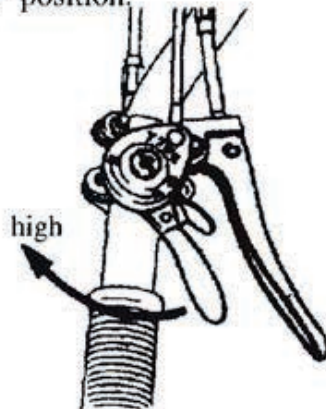

* Put the electric starter switch to the "Start" position.

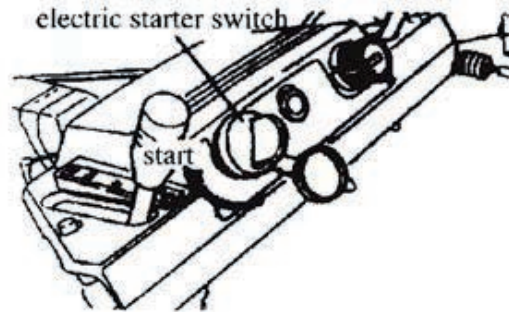

* The engine must be kept working idly for five minutes continuously before applying the load onto it.

Attention

If the electric starting runs for over ten minutes and still the engine cannot be started, please turn the switch off and let the battery rest for a minute. After that, try starting again.

② Starting in cold weather

If the engine is difficult to start in cold weather, try and help the starting with the following method.

* Remove the rubber plug in the cylinder head and add 2cc of engine lubrication oil.

* Put back the rubber plug and tighten it. Try starting the engine again. Or follow the instructions given on Page 17 in the instructions manual for the F series diesel engine.

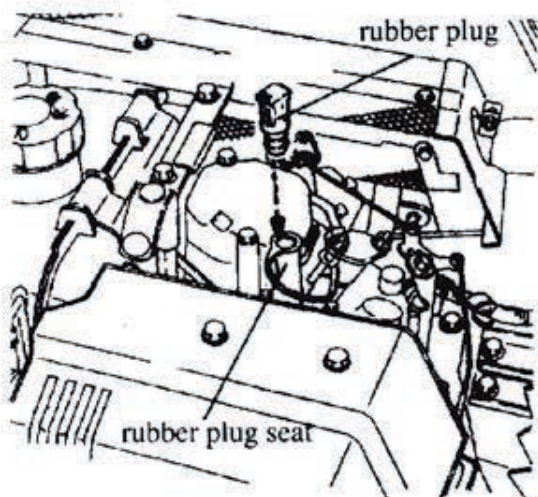

③ Manual recoil-type starting

If your machine is not equipped with electric starting or if the electric power is not sufficient to make a starting, try starting the engine with the following method.

* Perform the first four steps in "Normal Starting".

* Pull up the manual starting lever repeatedly until your hand feels a big load (i.e. in the compression state). Then let the lever go back to its original position automatically.

* Pull the pressure-reducing lever to the limit position (so that the pressure is reduced). Otherwise, repeat the above two steps.

* Hold the lever for manual recoil-type starting tightly with both hands and pull it up with force.

For further details, please refer to the description on Page 18 in the instructions manual for F series diesel engine.

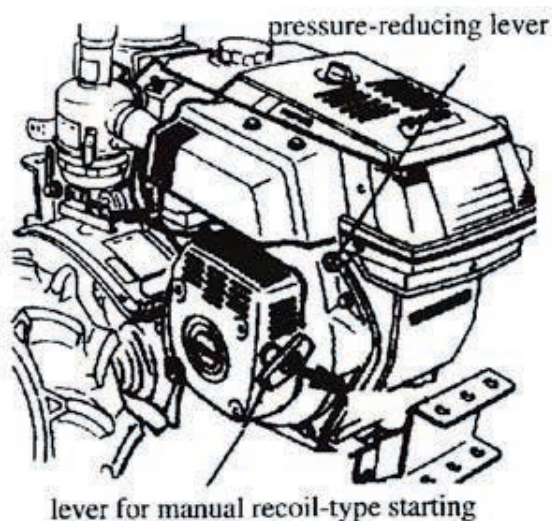

- ④ Shutting down of the engine
- * Set the throttle control lever to the "low" position.
 - * Put the electric starter switch to the "off" position to shut off the engine.

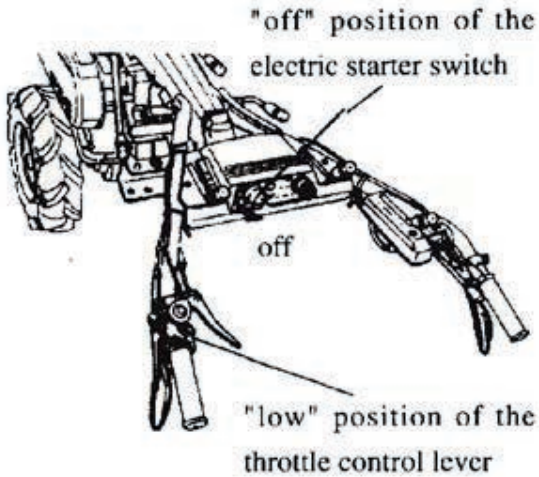

- * Put the fuel on/off switch to the "off" position.

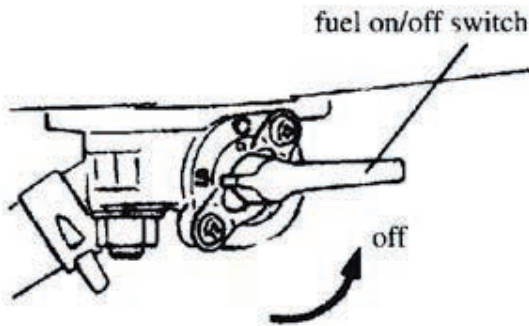

5. Methods of advance, turning, speed change and stopping

- ① Advance
- * Withdraw the front support

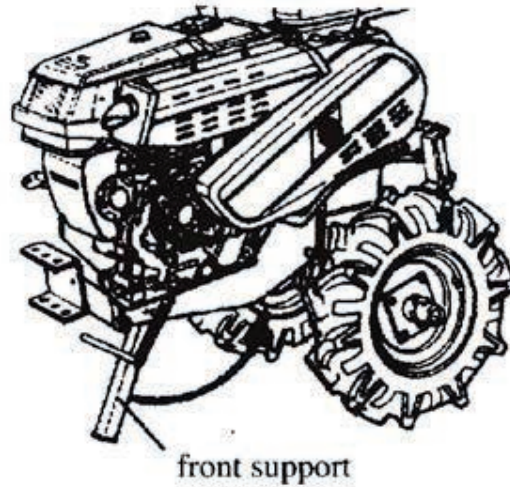

- * Select the speed for advance or backing with the main speed control lever.
- * Increase the speed of the engine a little with the throttle control lever.
- * Set the main clutch control lever to the "engaged" position so that the machine goes forward or backward.

Press down with your right thumb the auxiliary control lever for the engagement of the clutch, and you can control the engagement of the main clutch without taking your hand off the handle.

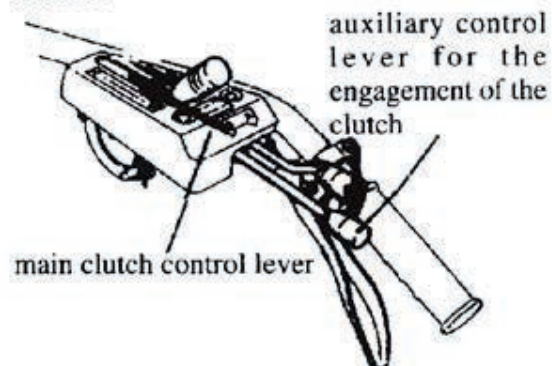

② Turning

* Hold tight the steering handle on the side you want to turn to, and make the turning.



* Use the handle for slightly changing the route of your advance.

③ speed change

Remember the following rule for changing the speed while running.

* Set the main clutch control lever at the "disengaged" position.



* Set the main speed change lever to the desired step.

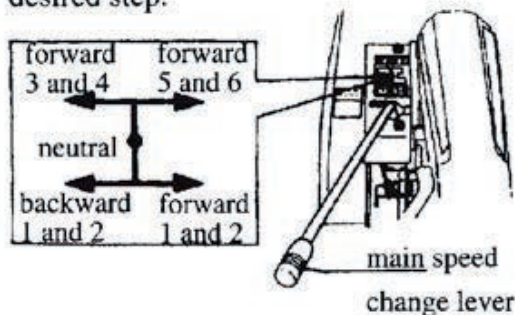

* Put the main clutch control lever to the "engaged" position and start going forward (or backward).

④ Stopping

* Put the main clutch control lever to the "disengaged" position so that the tilling manager stops working.

~ Press down with your right thumb the auxiliary control lever for the disengagement of the clutch, and you can control the disengagement of the main clutch without taking your hand off the handle.

* Pull the throttle control lever to the "low" position.

* Turn off the electric starter switch and stop the engine.

* Turn off the fuel on/off switch.

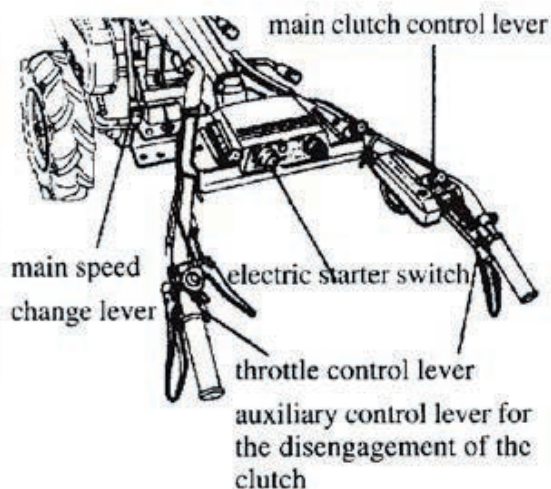

6. Loading and unloading

* Choose a flat place where there is no potential danger.

* Use a stepping board that meets the specifications.

Use a stepping board with sufficient strength and specified dimensions.
 * Length: at least 3.5 times as long as the height of the truck body
 * Width: matching the width of the truck
 * Strength: sufficient to withstand the weight of this machine.
 * Surface: treated so that it is not slippery

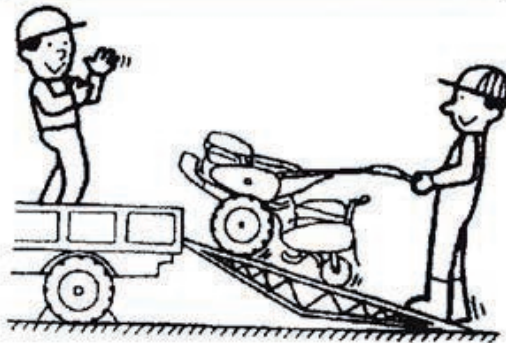

- * The stepping board and the truck body should be positioned correctly.
- * The left and right tires must be located at a distance from the edges of the stepping board. Put this machine on the stepping board, and loading or unloading may begin.
- * For loading, the speed should be set at the step of "forward 1", and for unloading at the step of "backward 1".
- * When the machine is put on a running truck, it must be securely bound with a strong rope. Its wheels must be stopped with wedges to prevent it from moving.



3.2 Correct Operation

1. Operation of the units related with its work.

① Adjustment of the height of the handle.

* The height of the handle can be finely adjusted to suit the height of the operator with the following method. Loosen the lockup lever for up and down fine adjustment of the handle. Make up and down adjustment to an appropriate height and then lock it up.

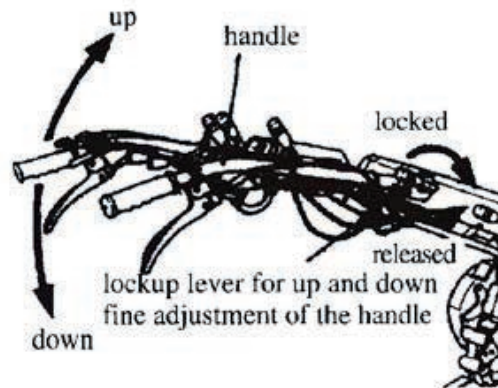

* If big adjustment is to be made during the operations, it is preferable to use the single-contact up and down adjustment lever.

* This lever can be set at three steps very quickly and conveniently.

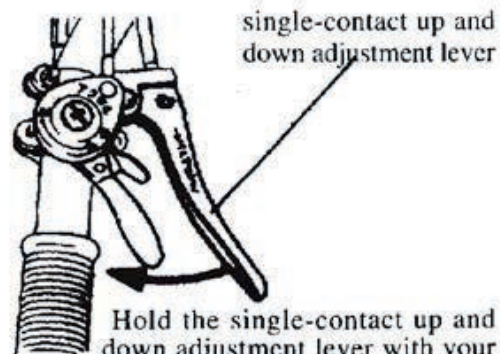

Hold the single-contact up and down adjustment lever with your hand and move it up and down for adjustment. Lock the lever when it is set at a desired position.

② Operation of the single-contact up and down adjustment lever

* Hold the single-contact up and down adjustment lever with you hand.

* Adjust the height of the handle to a desired position.

* Release the single-contact up and down adjustment lever and now the handle can be fixed and locked.

* When the position of the handle is not yet finalized, move it slightly up and down and you can fix it conveniently.

③ Horizontal adjustment of the handle by rotation within a range of 180 degrees

* Loosen the lockup lever for 180 degrees rotation of the handle and now the handle can be adjusted horizontally to a desired position at a ten-degree step within a range of 180 degrees. Then lock it up.

* The lockup is achieved by means of a saucer washer located in a slot seat and an eccentric shaft. So, just press down the lockup lever of the handle and you can fix it.

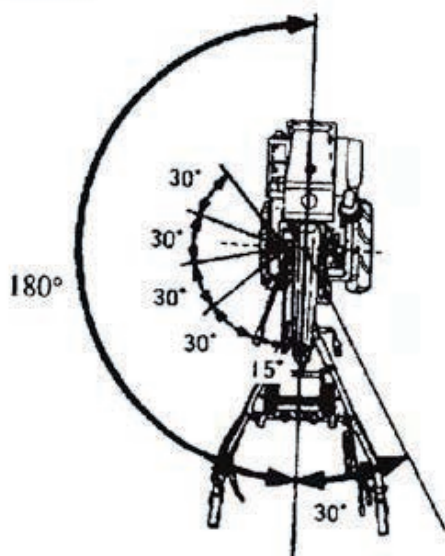

* To move the handle 30 degrees to the left, it is necessary to loosen the lockup lever for 180 degrees rotation of the handle first. After the adjustment is finished, lock up the lever again. Please note that in such a case, the main speed change lever should also be moved to the left a little.

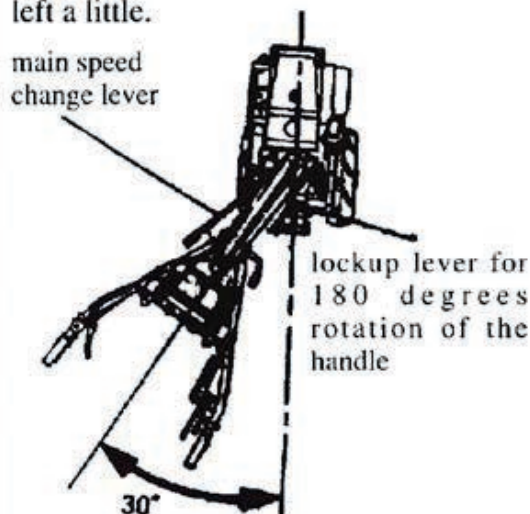

For ridge making, working on several beds and bank making in the fields, and for working indoors where many pillars make the operation very difficult, this machine can make the work very easy and convenient.

④ Working with the handle turned to the reverse direction

* When working with the handle turned to the reverse direction, it is necessary to rotate the turning switchover device controlling the manual handle 180 degrees at the same time (in the normal or reverse direction), so that the right and left steering levers are either switched over. If this switchover were not done, most likely the machine would turn to the wrong direction when he operates the steering lever, thus causing accidents or injury.

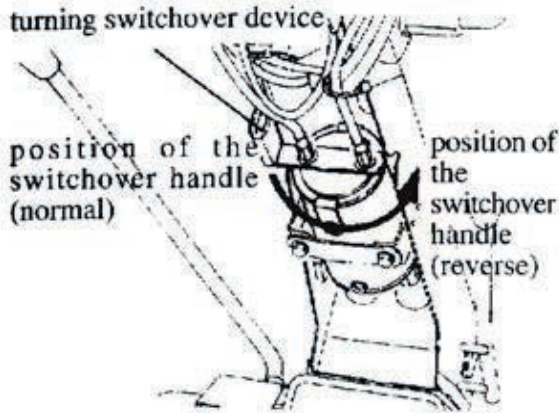

- * You can hear a clicking sound when the switchover is to the right position.
- * You must not hold the steering handle when you are making the switchover.

* Pull the main speed change lever upward, and push it back after the reverse switchover is finished. Now the steps for speed change are reversed. That means now there are two forward steps and six backward steps. To prevent using a high speed wrongly at the time of backing, it is necessary to loosen the backward high-speed limiter and lock the nut in the direction of the arrow as shown in the picture.

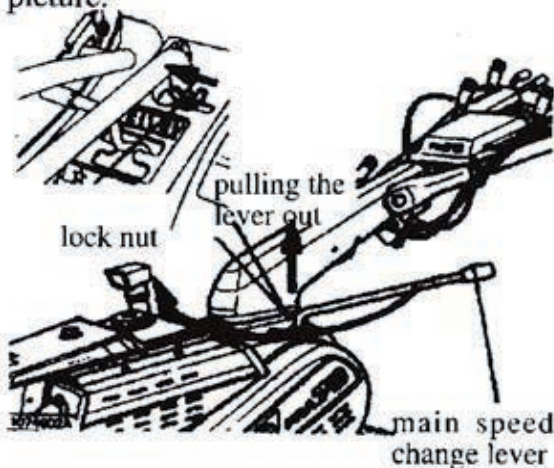

- * For the main speed change lever, the best operational position is at an angle of thirty degrees.

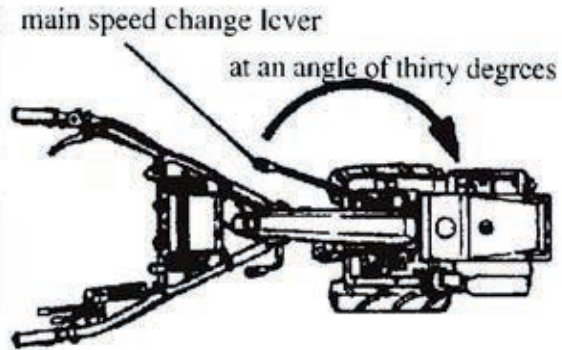

- * While using the handle in the reverse direction, take care not to touch the muffler when operating the main speed change lever.

2. Adjustment of the axle and the wheel base

The wheel base must be adjusted to meet the working conditions. By hooking a rotovator directly onto the shaft of the machine, it can work within very narrow beds in the fields.

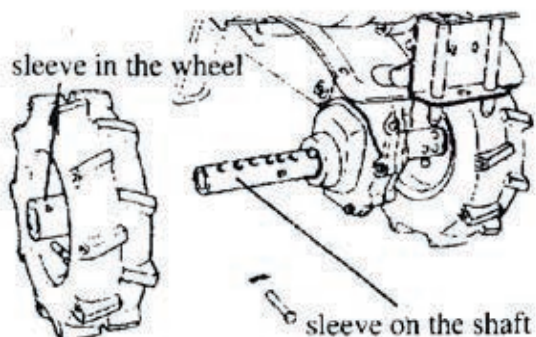

① Axle and wheel base on Models KM610/KM610E

Marking	Position of pin hole mm	WHEEL BASE: L (mm)	
		WHEEL SLEEVE (EXTERNAL)	WHEEL SLEEVE (INTERNAL)
A	257	206	308
B	365	314	416
C	415	364	466
D	473	422	524
E	531	480	582
F	589	538	640

* Wheel base means the distance between the centers of the wheels.

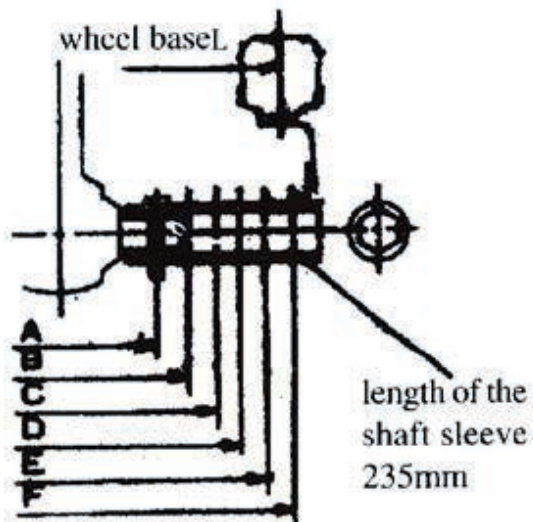

3.3 Correct Assembly and Use

1. Installation and use of the rotary tiller and its attachments

① rear hooking connector

The rotary tiller, resistance bar, banking machine and multi-functional attachments are to be hooked up with this connector.

rear hooking connector

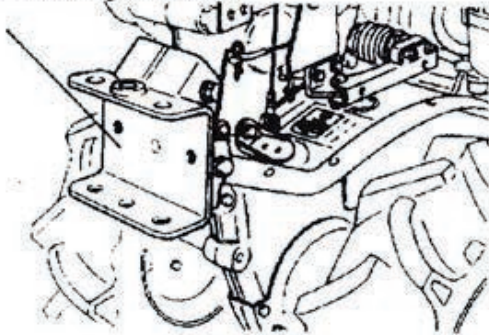

② front hooking connector

The front balance piece, front carrier and front working units are to be hooked up with this connector.

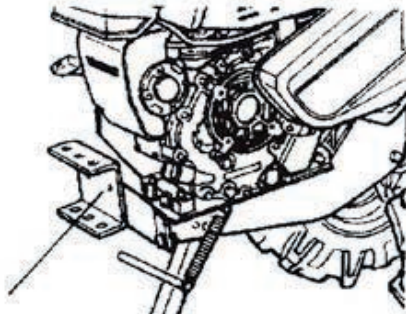

front hooking connector

③ Axle and shaft sleeve

The tires, a number of operating machines and attached wheels are to be connected here.

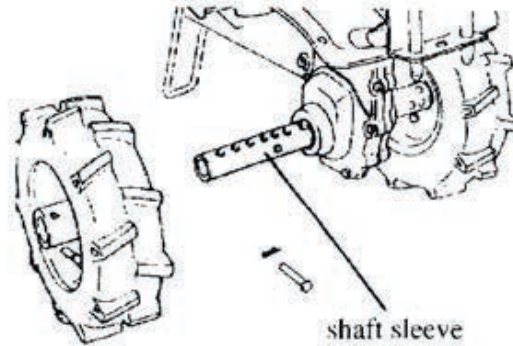

④ PTO shaft

The PTO shaft serves to transmit the power delivered by the engine. For this machine, it is an output shaft; for the operating machines, it is an input shaft.

It can be used when it is desired to use a rotary force such as that produced by the rotary tiller. In case no operating machine is connected, it will rotate when the main clutch is engaged. For the sake of safety, it must be guarded with a cover.

PTO shaft

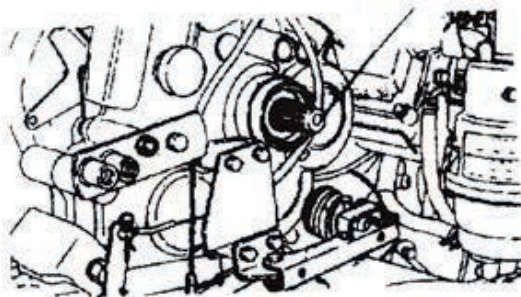

Attention: If the PTO shaft is not used, it must be well greased and protected with a cover.

2. Cautions for installing the rotary tiller
 Check that you are using the right type rotary tiller according to the bolts on the gearbox and the position of the flexible wire.

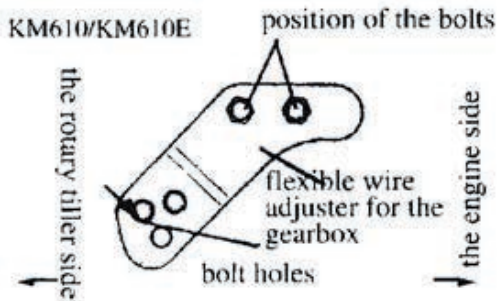

* For the installation of the rotary tiller, please refer to its own instructions manual.

3.4 Safety Precautions in Use

Watch for any possible leakage of the fuel

If the fuel pipes are broken, it might lead to fuel leakage. Be sure to check carefully. Otherwise, a fire might burst out. Broken fuel pipes must be replaced as soon as possible.



Remove over-spilled fuel

After refilling, the refilling port of the fuel tank must be tightly covered. All the over-spilled fuel must be cleared. Otherwise it might cause a fire.



Prevent the battery liquid from being spilled over your clothes or body
 If any battery liquid is spilled over your clothes or body, cleanse with water immediately. Otherwise, it might burn your clothes or skin.



Follow correct procedures when loading or unloading batteries
 Connect the positive pole first in loading and disconnect the negative pole first in unloading. Otherwise, there would be a creaking sound, and accidents of burning or fire might occur.



Check the machine at a flat place

If the machine is to be checked, choose a place where the traffic is perfectly safe, the ground is flat and hard, and the machine will not be subjected to tilting or vibration. If not so, the machine might turn over or other unexpected accidents might occur.



Stop the engine first before removing foreign substances

Before changing belts or sprockets or removing weeds caught in the machine, the engine must be stopped first. Otherwise unexpected accidents might occur.

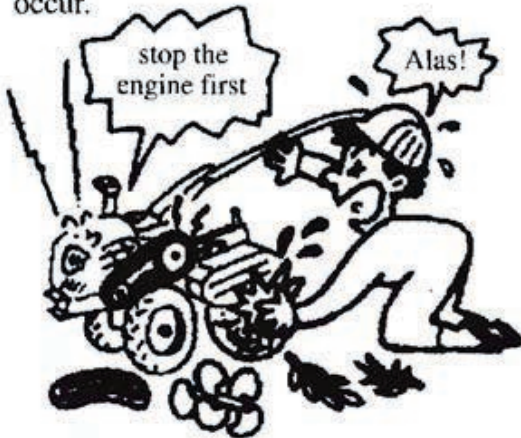

Never let anybody get near when starting the engine

Never allow anybody to get near the machine when doing operations in the fields or gardens. Otherwise, unexpected accidents might occur.

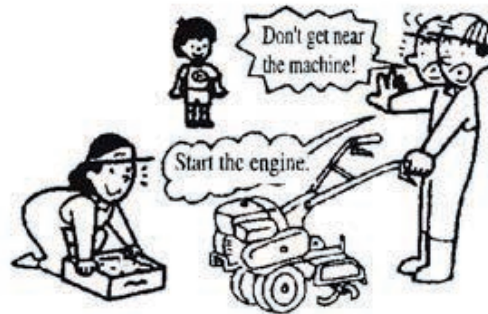

Make checks after the machine has cooled down

If it necessary to perform a check on the machine, stop the engine first and wait until the muffler, the engine and other overheated components cool down. Otherwise, there is a danger of getting burned.

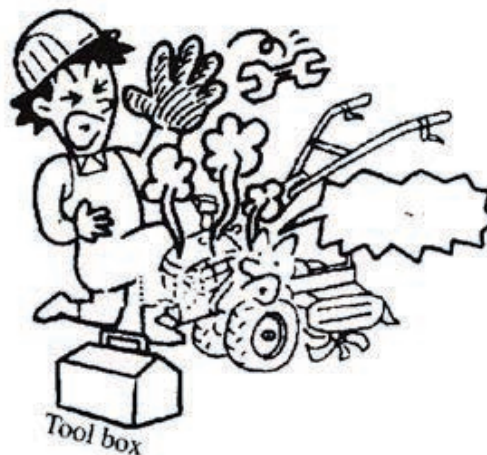

Chapter 4 Maintenance

4.1 Daily Maintenance

1. Daily maintenance after use

Rinse the machine with water after work every day, and then dry it completely. All the rotating and moving parts must be lubricated. In rinsing the machine, however, take care to prevent water from getting into the suction port of the air filter.

Stop the engine and wait until the heated parts cool down before doing daily maintenance.

2. Methods of lubrication

Lubricate all the lubrication points periodically.

① The pivoting points of the handle lockup lever and the lockup lever for 180 degrees rotation of the handle.

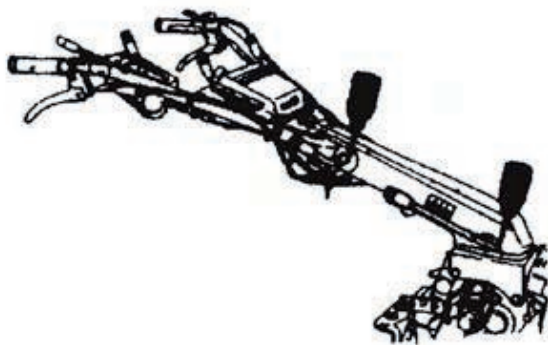

② The roller of the main clutch, the pivoting point of its operation lever and the adjusting point of the flexible wire adjuster.

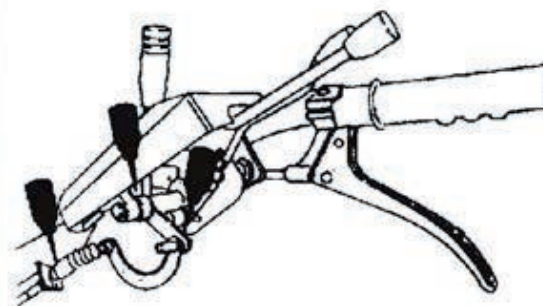

③ The pivoting points of the steering levers and the operation levers, and the adjusting point of the flexible wire adjuster.

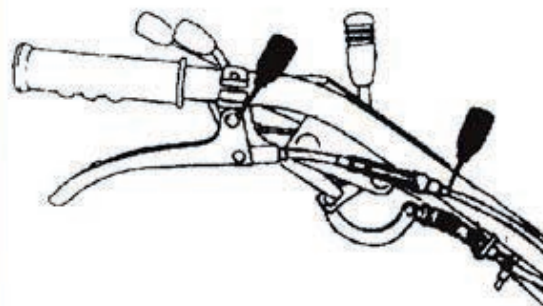

④ The pivoting point of the speed change lever

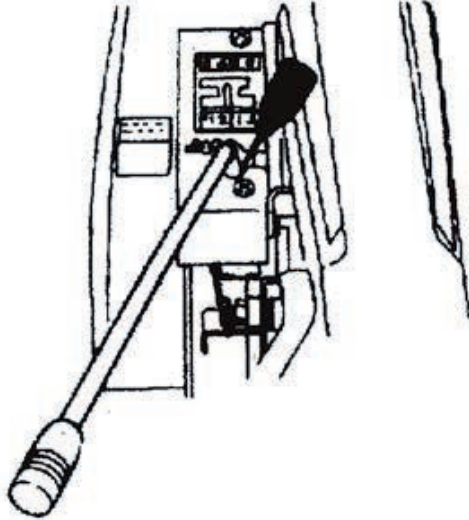

⑤ The pivoting point of the support

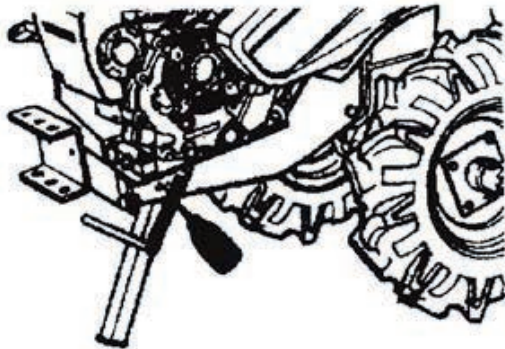

⑥ The pivoting points of the auxiliary speed change rods

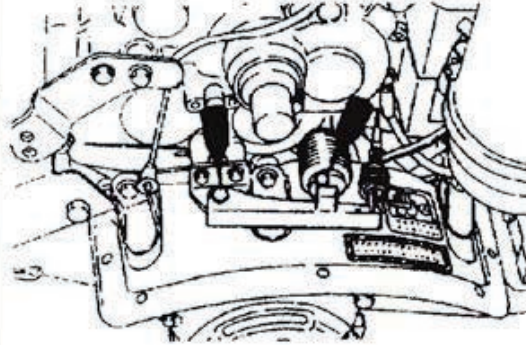

⑦ The pivoting points of the auxiliary speed change lever and the operation lever of the rotary tiller clutch, and the adjusting point of the flexible wire adjuster.

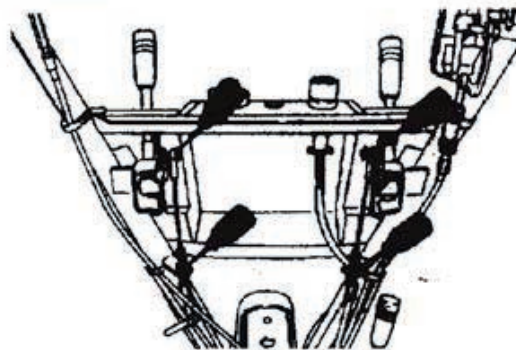

4.2 Periodic Maintenance

It is preferable to make periodic checks in slack tilling seasons so that the machine can work efficiently in busy seasons. Periodic check must be performed in order to prevent accidents caused by malfunction of the machine and guarantee the safe operation of all the units. In particular, fuel pipes and rubber components should be replaced every year. The electric circuits should be checked every year, to guarantee the machine works in the best conditions.

1. Schedule for periodic check

POSITION FOR CHECK AND ADJUSTMENT	SPECIFICATION	CHECK	SCHEDULE	REFERENCE
Engine mobile oil	KM610/KM610E 1.1L	CC class, S.A.E. 10W #30 (autumn and winter time)	The first time: after 20 hours. After that every 100 hours	P15 and 23 in the manual for F series diesel engines
Replacement of gear oil in the gearbox	KM610/KM610E 3.2L	Gear oil in the gearbox	The first time: after 50 hours. After that every 200 hours	P37
Cleaning of the fuel filter			Clean every 50 hours. Replace every 1000 hours	P36
Steering handle	1-3mm	Free movement of the operation lever		P39
Main clutch control lever	3-6mm	Clearance between belts and tension adjusters		P39
Control lever of rotary tiller clutch		State of the operation lever		P40
Control lever for auxiliary speed change	0mm	Clearance of the flexible wire adjuster of auxiliary speed change		P40
Air pressure in the tires	1.2kg/cm ²			P41
Connector bolts		Lockup		P41
Engine bolts		Lockup		P41
Lockup lever of the handle		Lockup		P18
Cleaning of the air filters	0.11L	Bearing oil		P37

2. Check and replacement of lubricants at various positions

Overused lubricating oil might deteriorate the mechanical performance of the machine. It also frequently causes faults. The waste oil must be periodically replaced with new oil of the specified quantity.

① Check of the mobile oil in the engine

Take out the dipstick and wipe it clean. Put it back into the engine to check if the oil is sufficient.

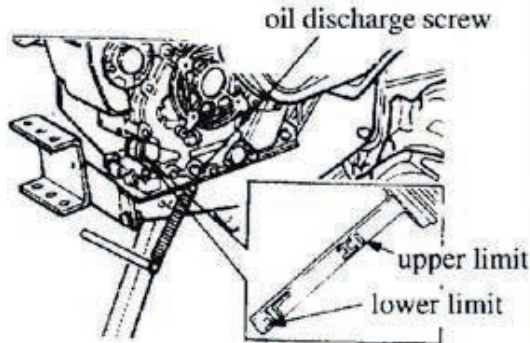

At the time of refilling, the engine must be put in the horizontal position.

Replacement: Screw out the oil discharge plug and drain all the used oil. Fill in the specified type of mobile oil of the specified quantity. For details, refer to Page 24 in the instructions manual for F series air-cooled diesel engine.

② Gear oil in the gearbox

Check: Check to see if there is any leakage

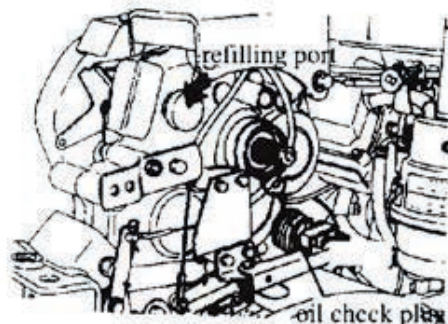

Replacement: Remove the oil discharge plug at the bottom part of the gearbox. Drain all the used oil and put back the oil plug. Then loosen the oil check plug and fill in new oil through the refilling port. Check the quantity of the oil filled through the oil check plug and tighten it as soon as new oil flows out of it.

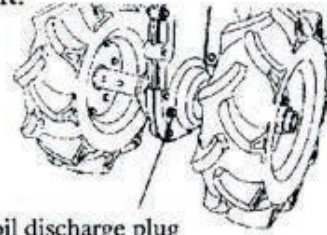

Location	Every 20 hours	Every 100 hours	Every 200 hours
Engine crankshaft chamber	The first time	The second time	
Gearbox		The first time	The second time
Mobile oil filter	Clean	Clean	Replace
Fuel filter		Clean	

3. Cleaning of the fuel filter

Take out the fuel filter from the fuel tank and clean it.

Cleaning	Every 500 hours
Replacement	Every 1000 hours

Cleaning procedures: (refer to the instructions on Page 24 of the manual for the F series air-cooled diesel engine)

- * Drain the diesel completely in the fuel tank.
- * Loosen the nut and remove the screw plug. Take out the filter.
- * Clean the element thoroughly with clean diesel and let it dry.
- * Install the filter in the reverse order as described above.

Attention: make sure at the time of assembly that the fuel filter has a rubber pad at its bottom.

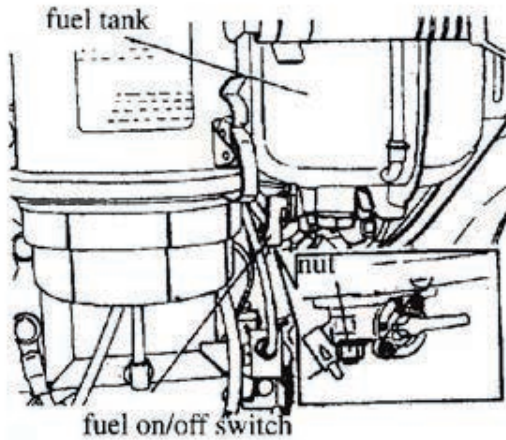

4. Cleaning and replacement of the air filters

Open the lock and take out the sponge component inside the filter. Clean it with white kerosene and shake it dry. Reinstall it. Contaminated filters might reduce the power generated by the engine and even cause malfunction or faults. Positions plugged by oil must be completely cleaned. Put in a specified quantity of new bearing oil.

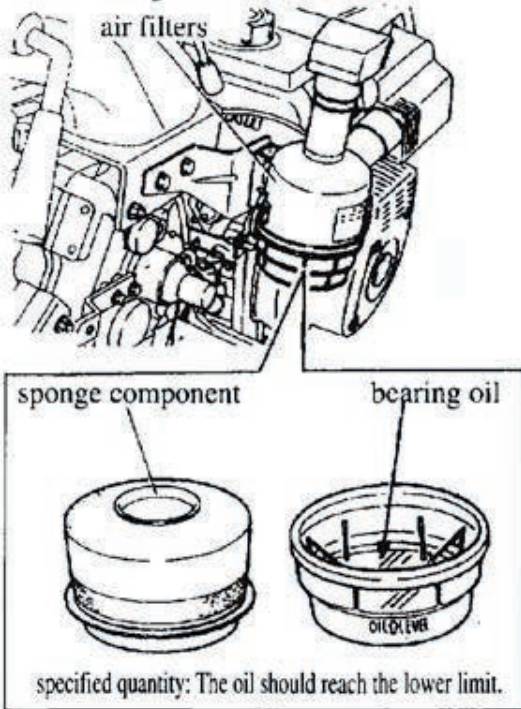

5. Cleaning of lubricating oil filters

- * Loosen the nut and take out the filter
- * Clean it with light diesel.

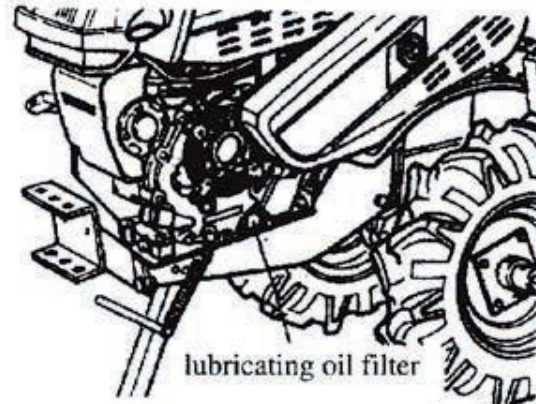

Cleaning	Every 100 hours
Replacement	Every 200 hours

* Refer to Page 24 in the instructions manual for F series air-cooled diesel engine.

6. Air bleeding from fuel pipelines

- * Fill the fuel tank with fuel
- * Turn on the fuel on/off switch and push the throttle control lever to the "high" position.
- * Pull out the pressure-reducing rod up to its end so that it is in a state of compression. Pull out the starter lever repeatedly until you can hear the creaking sound of compressing and fuel spraying.

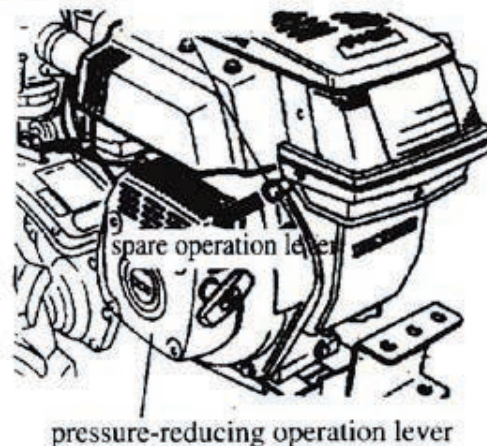

If the spraying produces abnormal noise, open the top cover. Press the pressure-reducing lever directly with one hand and take hold of the high-pressure pipe with the other, to see if there is the sound of spraying. For KM610/ KM610E tilling managers, press the pressure-reducing levers directly as described above.

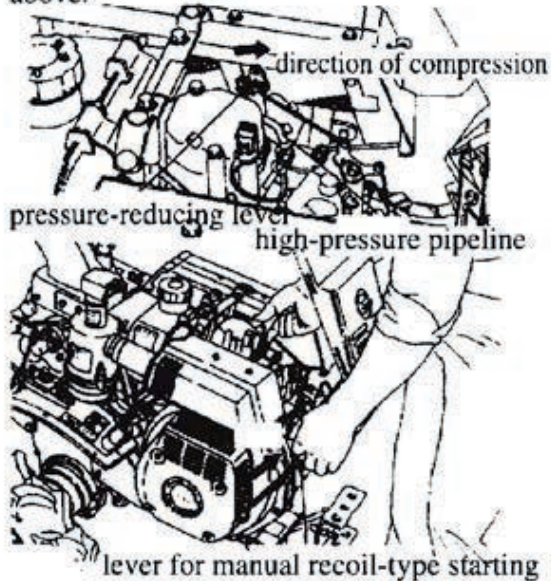

4.3 Adjustment and Maintenance of Different Units

1. Water removal and cleaning of the fuel tank

Water might be accumulated in the fuel tank because the fuel is pure enough. It will cause contamination. Remove it with the following method.

* Loosen the oil discharge plug at the exhaust port slowly with a 17" spanner. It is better to drain the accumulated dirty water little by little.

* When the dirty water is completely drained, tighten the oil discharge plug.

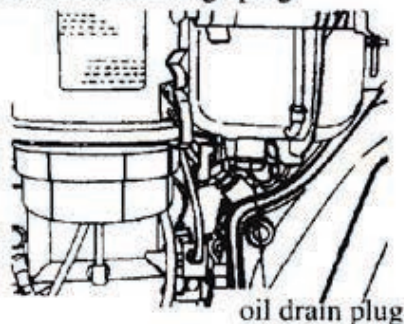

2. Check and replacement of the fuse
Fuses, which will melt and break at high temperature, are components protecting electric circuits from overload.

* Open the front cover.

* A fuse socket can be found at the top front of the engine. If the fuse is found broken, it must be replaced.

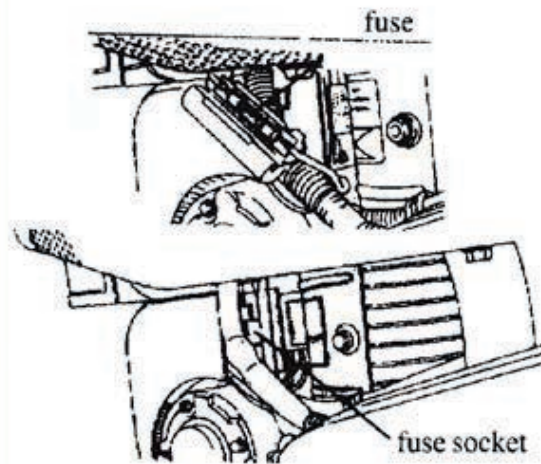

3. Adjustment with flexible wire adjusters for various controls

① Turning switchover device controlling the manual handle

Take out the flexible wire adjuster in the steering handle. Adjust the clearance of the flexible wire adjuster of the gearbox right by the handle. After the clearance gets to zero, adjust the flexible wire adjuster for the steering handle.

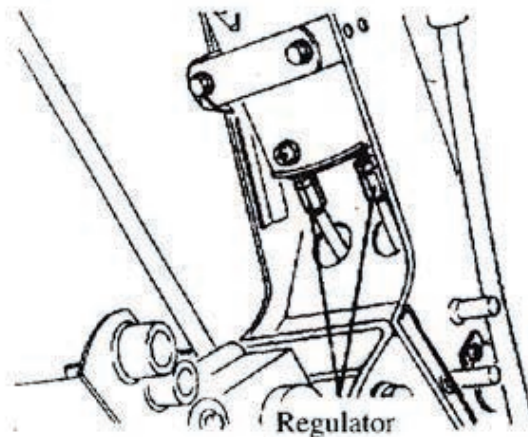

② Steering handle

Check: Take hold of the steering handle and check that the clutch is in the state of disengagement. In such a case, you can easily press down the steering handle.

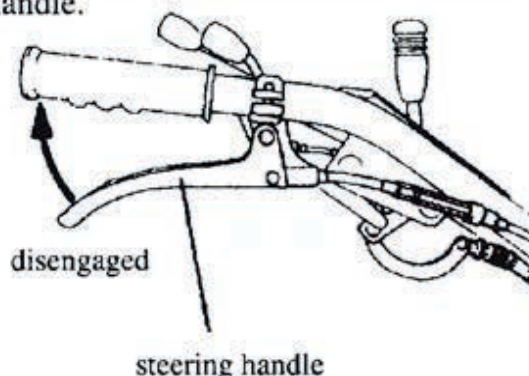

Adjustment: When the steering handle is 10 mm (dimension A) from the handle of the machine, the clutch is disengaged. Adjust with the flexible wire adjuster on the steering handle.

In a natural state (i.e. without taking hold the steering handle), the clearance should be 1-3 mm (dimension B).

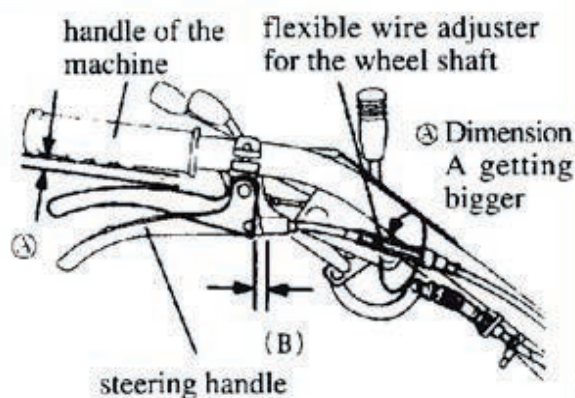

Attention: After adjusting the steering clutch, you must confirm that it works properly and reliably.

③ Main clutch control lever

Check: The functions of engagement and disengagement must be OK and reliable. In the state of disengagement, make sure that the belt pulley does not rotate with the belt. The auxiliary control levers for the engagement/ disengagement of the clutch control lever must be able to work properly. The engagement/disengagement of the main clutch must be reliable.

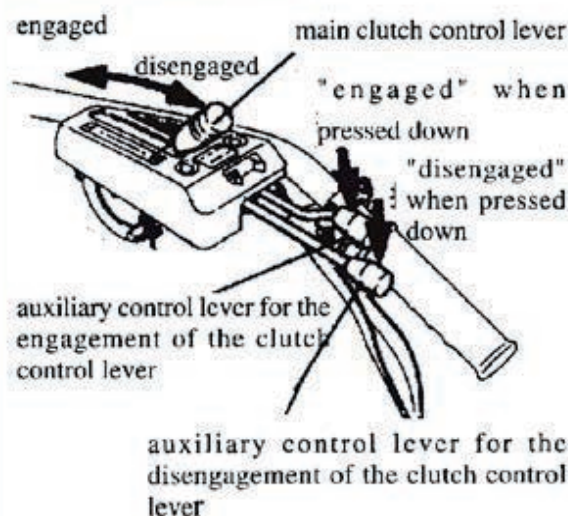

Disengagement of the main clutch: Press down the auxiliary control lever for disengaging the clutch with your right thumb, the main clutch control lever should be put to the state of disengagement.

Engagement of the main clutch: Press down the auxiliary control lever for engaging the clutch with your right thumb, the main clutch control lever should be put to the state of engagement.

Adjustment: In operations, adjust until the belt pulley does not slip. Adjust the clearance with the flexible wire adjuster of the main clutch. If the adjuster cannot be further adjusted, move the engine forward so that the main clutch control lever is put in the state of engagement. The clearance between the belt and the belt tension adjuster should be adjusted to 3-6 mm.

main clutch control lever

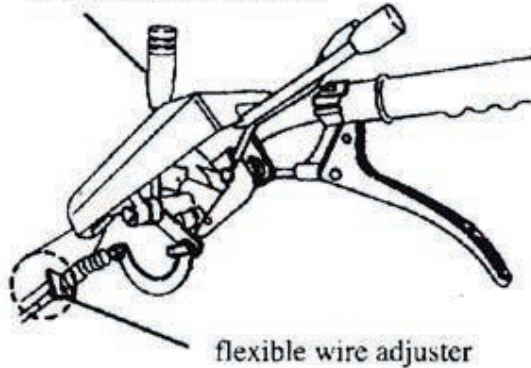

flexible wire adjuster

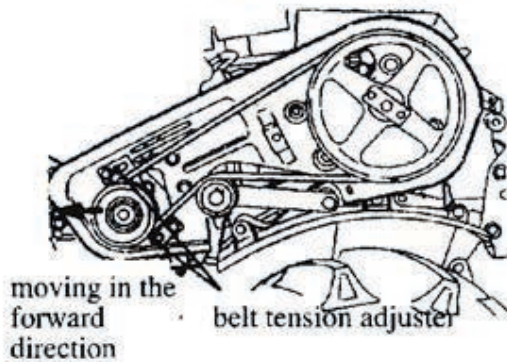

moving in the forward direction

belt tension adjuster

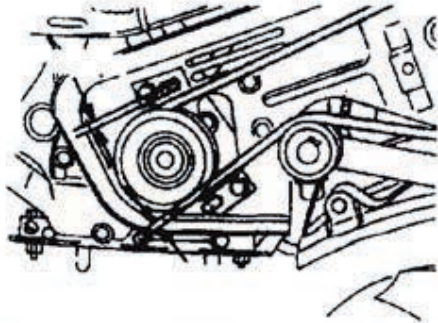

④ Rotary tiller clutch control lever (to be used when the rotary tiller is installed)

Check:

* Check if the spring at the front end of the flexible wire adjuster on the side of the rotary tiller is securely connected with the rocker arm on the side of the tilling manager.

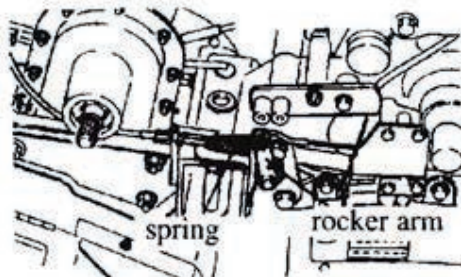

spring

rocker arm

* Put the control lever in the "disengagement" position and check if the rotary tiller stops rotating.

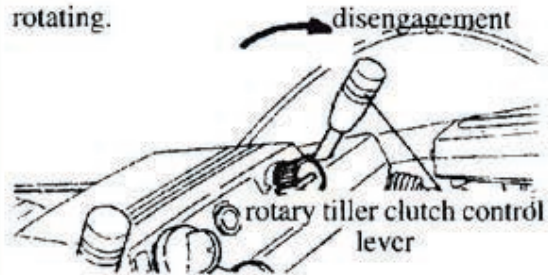

disengagement

rotary tiller clutch control lever

Method of adjustment

* Adjust with the flexible wire adjuster so that it is possible to practice reliable control over the engagement and disengagement upon the rotation of the rotary tiller.

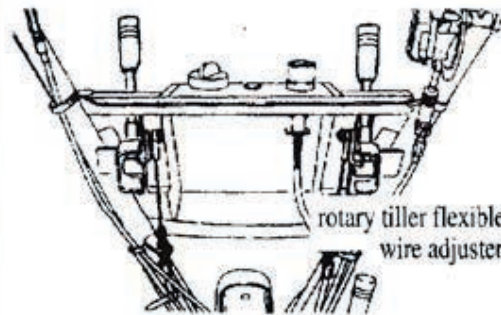

rotary tiller flexible wire adjuster

* Put the rotary tiller clutch control lever in the position of disengagement, and stop the engine. Rotate slowly with your hand the rotary claws on the rotary tiller and check if they can move freely.

⑤ Auxiliary speed change control lever
Check if it is possible to switch reliably between the positions of "high" and "low".

auxiliary speed change control lever

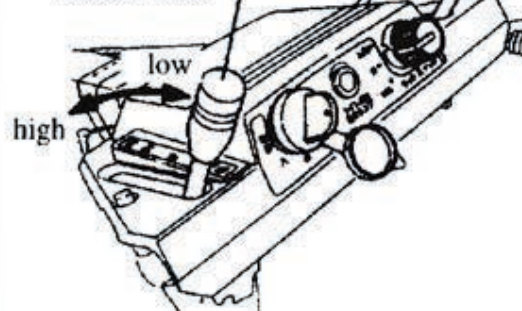

high

low

Method of adjustment

Put the auxiliary speed change control lever in the "high" position and adjust, with the help of the flexible wire adjuster, the clearance between the auxiliary speed control lever and the end of the speed control yoke shaft to about zero.

※ At the position of "high", it should be impossible to push the auxiliary speed control lever into the speed control yoke shaft. Please check this point carefully.

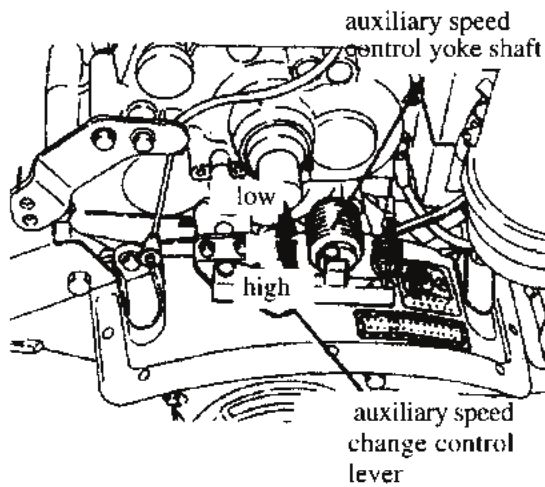

4.Adjustment of the tire pressure

* The pressure in the right and left tires should be adjusted to 1.2kg/cm².

* If the pressure settings in the right and left tires are not equal, it would be very difficult to control the handle and drive in a straight line in operations.

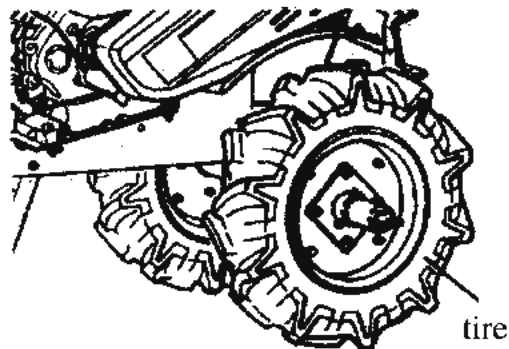

5.Lockup positions

① Locking bolt in the hooking connector

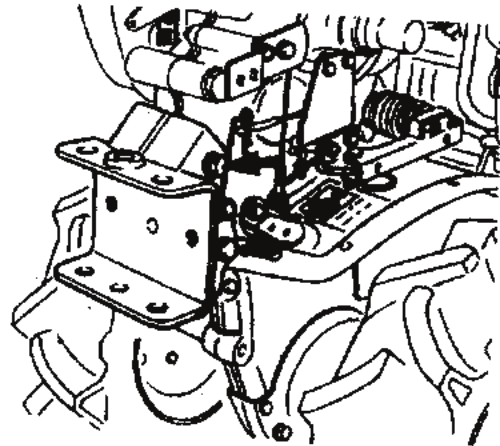

② Locking bolt of the engine

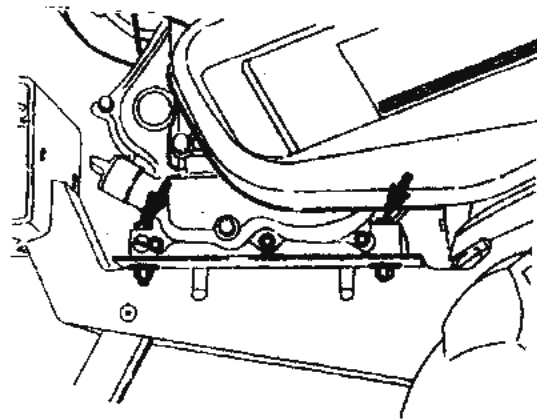

③ Lock bolt for the support of the handle

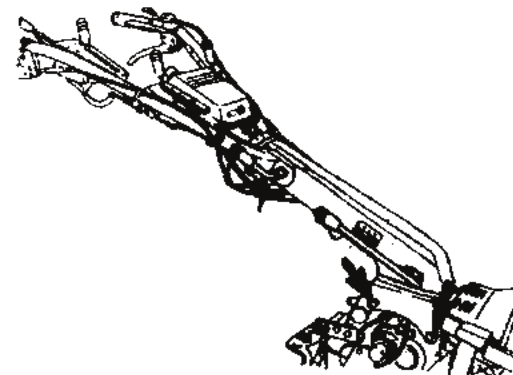

6. Check on the pipelines and electric circuits

* If an oil pipeline is found to be broken or a fitting is found to be loose, check if there is any leaking.

* Check if the connectors in the electric circuits are in touch with other components and if they are squeezed, damaged or loose. If oil pipes or electric connectors are found to be damaged, please contact our agents, retailers or service centers for repair or replacement. They must be replaced every two years even if they are not damaged.

Attention: If the oil pipes are aged or damaged, fuel might leak out. Then a fire may break out if there is a flame nearby. Make a careful check before and after operations and replace them as soon as leaking is found.

① Maintenance of the battery

* Before operation, check the liquid level in the battery and make sure that it should be between the upper and lower limits. (Please refer to the instructions on Page 19 in the manual for the F series diesel engine.)

* If the liquid level in the battery is found to be insufficient, please add a little distilled water.

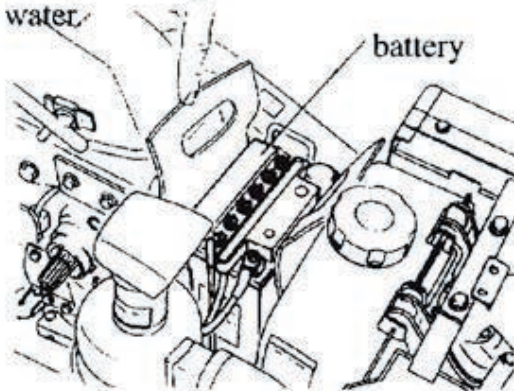

* In cold weather, if it is difficult to start the engine and the lights are found to be dim, please recharge the battery.

* If the machine is not operated for more than two weeks, the electricity in the battery may discharge. In such a case it would be difficult to start the engine. You would have to recharge the battery or start the engine manually.

* If the machine is not used for a long period of time, it is advisable to recharge the battery at least once a month. This will help to prolong the service life of the battery.

Attention: If the liquid level in the battery is above the upper limit, it might leak out in operations and corrode the components in the machine. Take care to prevent this when you add liquid into the battery.

② Recharging of the battery

* When you recharge the battery, you should connect the positive pole of the battery to the positive pole of the charger, and connect their negative poles together. Please read the instructions for the charger carefully before start recharging.

* It is advisable to use normal recharging instead of quick recharging.

Attention: The terminals of the battery should be protected with grease when it is not in use. When you install the battery, clean the terminals thoroughly with oil.

③ Storage of the battery

* In storage, the battery should be put on a flat surface so that no liquid might leak out. If the battery is kept in storage for a long period of time, take down the negative lead and take out the battery. The battery should be kept at a dry place not exposed to direct sunshine.

4.4 Storage

If you want to put the machine in storage, follow the following steps.

- * Run the engine at low speed for about five minutes.
- * Drain all the lubricating oil while the engine is hot.

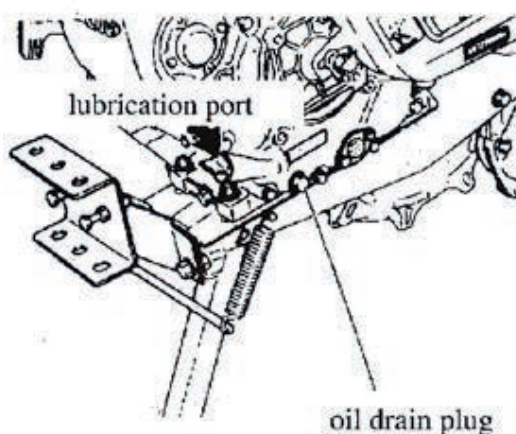

- * Take out the rubber plug on the cylinder head and add 2 cc of lubricating oil. Put the pressure-reducing control lever at the non-compression position. Pull the lever for manual recoil-type starting two or three times (without starting the engine however).

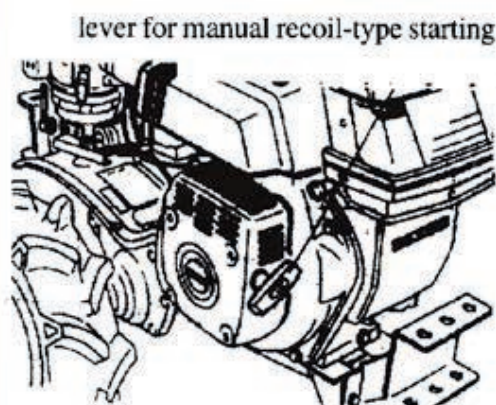
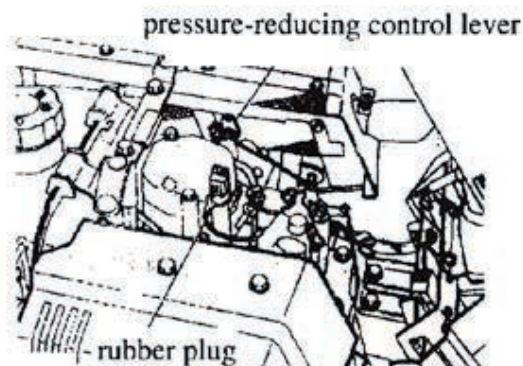

- * Put the pressure-reducing control lever at the compression position. Pull up the lever for manual recoil-type starting slowly and stop while kept at the compression position. In this condition, the air inlet and outlet valves are shut off. This can prevent moisture from getting into the engine and causing rust.
- * Take care to prevent mud or other contaminants from getting the machine. Keep the machine at a dry place.

Chapter 5 Fault Finding

If a fault occurs, check the machine after the engine is shut off according to the following chart.

CAUSE	CHECK	REMEDY
Engine not running	Is fuel used up?	Add fuel.
	Is the starting procedure wrong?	Start the engine in the correct way. Follow the instructions on Page 17 in the manual for F series diesel engine.
	Is there water in the fuel tank?	Drain water with the plug at the bottom part of the engine.
	Is the engine well compressed?	Use the lever for manual recoil-type starting instead of the pressure-reducing lever. Contact our agent or service center.
	Can the fuel be sprayed?	Discharge the air.
	Does the battery have enough power?	Check the battery and recharge if necessary.
	Is the liquid level in the battery sufficient?	Add liquid into the battery.
	Is the fuse broken?	Replace the fuse (10A).
Engine does not produce enough power	Is the air filter plugged?	Take out the sponge component and clean it with white kerosene. Add new bearing oil
	Is there enough mobile oil in the engine?	Add new mobile oil. If the oil has been used for a long time, replace it. See Page 37.
	Is the clearance too big with the spare parts?	Use proper spare parts.
	Is the belt too loose?	Adjust the tension of the belt. See Page 41.
	Is the engine speed too high?	Adjust the length of the throttle flexible wire adjuster.
	Is the engine compressed?	Lock related screws tight (like those on the cylinder pads).
		Replace the piston ring and scraper ring.
Too much vibration	Is the vibration caused by the engine?	Tighten the bolts on the engine.
	Does the handle vibrate?	Tighten the bolts on the handle.
	Is the vibration caused by the attachments?	Align the attachments with the machine. Tighten their bolts and nuts.

